

MARC2020:

Microsystems Annual Research Conference



January 28-29, 2020
Bretton Woods, NH

MARC2020:

MICROSYSTEMS ANNUAL RESEARCH CONFERENCE

JANUARY 28-29, 2020 • BRETTON WOODS, NH

MARC2020 CONFERENCE ORGANIZERS

Mayuran Saravanapavanantham, Conference Co-Chair
Rachel Yang, Conference Co-Chair

CORE COMMITTEE

Audio/Visual Management Chair
Miaorong Wang

Website and Proceedings Chair
Jatin Patil

Communications Training Committee

Jessica Boles
Deanna Montgomery, EECS Communication Lab Manager
Reyu Sakakibara

Social Activities Chair

Elaine McVay

Transportation/Winter Activities Chair

Jay Sircar

Outreach Chair

Morteza Sarmadi

Registration/Logistics Chair

Rishabh Mittal

Photography/Videography Chair

Navid Abezadeh

TECHNICAL SESSIONS

Circuits: Integrated Electronics, Energy Efficient AI, and Systems Committee

Jane Lai, Session Chair
Gladynel Saavedra-Pena
James Noraky

Electronic & Quantum Devices 1 Committee

Qingyun Xie, Session Chair
Nadim Chowdhury
Joshua A. Perozek

Nanotechnology & Nanomaterials, Materials & Manufacturing Committee

Haozhe Wang, Session Chair
Jiahao Han
Kuan Qiao
Zhe Shi
Qichen Song

Medical Devices & Biotechnology, Electronic & Quantum Devices 2 Committee

Kruthika Kikkeri, Session Chair
Wei Liao

Photonics & Optoelectronics Committee

Mohamed Ibrahim, Session Chair
Isaac Harris
Sally Elhenawy

STEERING COMMITTEE

Hae-Seung (Harry) Lee, MTL Director
Jesús A. del Alamo, Former MTL Director
Vladimir Bulović, MIT.nano Director
Stacy McDaid, Administrative Officer
Katrina Mounlavongsy, Human Resources Administrator
Jami Mitchell, Publications & Proceedings
Amanda Stoll, Publications & Proceedings
Joseph Baylon, Organization & Logistics
Shereece Beckford, Organization & Logistics
Paul McGrath, Photography

First printing, January 2020
PDF version 2.0, January 2020

Microsystems Technology Laboratories
Massachusetts Institute of Technology
50 Vassar Street; Building 38, Room 246
Cambridge, MA 02139
mtl.mit.edu

MIT.nano
Massachusetts Institute of Technology
60 Vassar Street (Rear); Building 12-5025
Cambridge, MA 02139
mitnano.mit.edu

© Massachusetts Institute of Technology

CONTENTS

- Introduction i
- Agenda..... ii
- Day 1: Keynote - Reed Sturtevant..... iv
- Day 2: Keynote - Mark Rosker..... v
- Industry Consortium (MIG & MAP Members)..... vi
- Poster Sessions..... vii
 - Session 1: Circuits: Integrated Electronics, Energy Efficient AI, and Systems 1
 - Session 2: Energy Harvesting and Storage..... 9
 - Session 3: Electronic and Quantum Devices 1..... 15
 - Session 4: Nanotechnology and Nanomaterials 23
 - Session 5: Medical Devices and Biotechnology 31
 - Session 6: Electronic and Quantum Devices 2..... 35
 - Session 7: Photonics and Optoelectronics..... 43
 - Session 8: Materials & Manufacturing 51
- Maps 57

INTRODUCTION

Dear colleagues,

Welcome to the 16th Microsystems Annual Research Conference, MARC2020! We are excited to have you with us at the Omni Mt. Washington Resort in Bretton Woods, NH.

Over the past few decades, MARC has seen many changes. The conference has its roots in the VLSI Research Reviews, later known as the Microsystem Technology Laboratories (MTL) Annual Student Review, under the guidance of Prof. Paul Penfield in 1990. This annual meeting was initially faculty-run and more casual in nature. In 2005, under the guidance of Prof. Anantha Chandrakasan, the meeting evolved into the more formalized, student-run conference it is today. Through all these changes, MARC has grown into an invaluable opportunity for students, faculty, industry partners, and other MTL-affiliated associates to discuss research and establish relationships, especially with people outside their day-to-day interactions.

This year, MARC finds itself in yet another transitional period. For the first time, MARC2020 is co-hosted by MTL and MIT.nano. Through this partnership, the conference welcomes future trends in nanoscale research to complement MTL's existing research and opens the benefits of MARC to a broader community, including several new industry partners. By transitioning into a joint conference, MARC gains new opportunities to grow in the coming years.

As we kick off the new decade, we invite you to look forward to the future at MARC2020 as we strive for cutting-edge research achievements and technological innovation. From our distinguished keynote speakers, Reed Sturtevant, General Partner at the Engine, and Dr. Mark Rosker, the Director of DARPA's Microsystems Technology Office, we'll get a glimpse into how start-ups transition groundbreaking research from the bench to the real world and how large government organizations lay out critical problems to tackle. We also welcome new forms of media to the conference with virtual reality social activities that include a virtual tour of MIT.nano and a 2D materials demo.

At the start of this new chapter, MARC2020 continues to host a wide variety of research presentations with over 90 abstracts from 36 different research groups. This year, the conference also features eight demos, a record-high for MARC.

Of course, MARC2020 would not be successful without a large supporting community. We thank all the authors for submitting abstracts, presenting posters, and delivering pitches. We thank the members of the Microsystems Industrial Group and MIT.nano's Member Advisory Panel for their support and participation in the conference. We thank the faculty for their time, especially for attending the conference to support the students. We are also incredibly grateful to those who helped us organize this conference, including the student committee, volunteers, and administrative staff from MTL and MIT.nano. Last but not least, we thank Professors Jesus del Alamo, Hae-Seung (Harry) Lee, and Vladimir Bulović for their work and guidance to help make MARC2020 possible.

We hope you enjoy MARC2020!

Sincerely,

Mayuran Saravanapavanantham and Rachel Yang
MARC2020 Co-Chairs

AGENDA

DAY 1: JANUARY 28

7:00 am **Morning Bus Departs MIT** 60 Vassar Street, Cambridge, MA

10:00 am–4:00 pm **Winter Activities** Bretton Woods, NH
Our attendees can take part in a variety of outdoor winter activities on Mount Washington as well as indoor activities.

12:00 pm **Afternoon Bus Departs MIT** 60 Vassar Street, Cambridge, MA

3:00 pm–5:00 pm **Check-in & Registration** Great Hall
Conference check in - MARC2020 Registration Desk
Hotel check-in - Hotel front desk

3:30 pm–5:00 pm **Pitch Practice and AV Check** Presidential Ballroom

5:00 pm–6:00 pm **Welcome Reception** Conservatory

6:00 pm–7:15 pm **Dinner Banquet** Grand Ballroom

7:15 pm–8:15 pm **Evening Keynote** Grand Ballroom
Reed Sturtevant, The Engine - General Partner

8:15 pm–8:30 pm **Group Photo** Grand Ballroom

8:30 pm–10:45 pm **Evening Activities** Washington, Jefferson, and Reagan Rooms
Dessert and coffee will be served

9:00 pm–10:45 pm **Pitch Practice and AV Check** Grand Ballroom

AGENDA

Day 2: January 29

8:15 am–9:00 am	Breakfast Dining Room
9:00 am–9:20 am	Opening Remarks Grand Ballroom The technical portion of the conference begins with an MIT.nano community update.
9:20 am–10:05 am	Technical Keynote Grand Ballroom Mark Rosker, DARPA - Microsystems Technology Office Director
10:05 am–10:15 am	Coffee Break Grand Ballroom Lobby
10:15 am–10:45 am	MIG/MAP Pitches Grand Ballroom
10:45 am–11:30 am	60-Second Poster Pitch Presidential Ballroom Session 1 - Circuits : Integrated Electronics, Energy Efficient AI, and Systems Session 2 - Energy Harvesting and Storage Session 3 - Electronic and Quantum Devices 1 Session 4 - Nanotechnology and Nanomaterials Session 5 - Medical Devices and Biotechnology
11:30 am–12:45 pm	Poster Session Conservatory Sessions 1, 2, 3, 4, and 5.
12:45 pm–2:00pm	MIG/MAP Networking Lunch Dining Room
2:00 pm–2:45 pm	60-Second Poster Pitch Grand Ballroom Session 6 - Electronic and Quantum Devices 2 Session 7 - Photonics and Optoelectronics Session 8 - Materials and Manufacturing
2:45 pm–4:00 pm	Poster Session / Coffee Break Conservatory Sessions 6, 7, and 8.
4:00 pm–4:30 pm	Closing Ceremony Grand Ballroom Award presentations and a final note from our organizers.
4:30 pm–5:00 pm	Buses Depart for MIT Hotel Main Entrance

DAY 1: EVENING KEYNOTE

Reed is a General Partner on the investment team at The Engine. Reed was a founder and Managing Director at Project 11 Ventures and Techstars Boston. He attended MIT and has a background in software. He ran Microsoft Startup Labs in Cambridge and was VP of Technology at Idealab, Boston. Early in his career he created Freelance Graphics which was acquired by Lotus Development Corp. He has been a lecturer at MIT Sloan and is a frequent speaker at MIT entrepreneurship courses and programs.



REED STURTEVANT

General Partner
The Engine

DAY 2: MORNING KEYNOTE



MARK ROSKER

Microsystems Technology
Office Director (MTO)
DARPA

Dr. Mark Rosker became director of DARPA's Microsystems Technology Office (MTO) in April 2019. Prior to this, he was deputy director of Defense Sciences Office (DSO) beginning in April 2018.

Prior to his most recent DARPA appointment, Dr. Rosker was a principal engineering fellow at Raytheon Space and Airborne Systems (SAS) in Rosslyn, Virginia, working to anticipate and recognize emerging technical directions and program opportunities within the government science and technology (S&T) community. From 2003 to 2011, Dr. Rosker was a program manager in DARPA's Microsystems Technology Office (MTO). As program manager, he developed a portfolio of technical programs in gallium nitride and other compound semiconductor radio frequency (RF) device technologies, heterogeneous circuit integration, terahertz electronics, and quantum cascade lasers. One of Dr. Rosker's programs, the Wide Band Gap Semiconductors for Radio Frequency Applications (WBGS-RF) program, was selected in 2016 for the prestigious "DARPA Game-Changer Award." In 2009, Dr. Rosker became the deputy director of MTO, and he ended his first tour as the acting office director.

Prior to 2003, Dr. Rosker worked in NASA's Jet Propulsion Laboratory (JPL) in Pasadena, California, where he was a member of the submillimeter wave advanced technology group. Dr. Rosker was also at the Rockwell Scientific Co. (now Teledyne Scientific) in Thousand Oaks, California, from 1989 to 2003. His technical work there was in researching nonlinear optics, including photorefractive oscillators and visible and infrared frequency conversion materials and devices, time-domain spectroscopy of optical materials, and optical power limiters. He later led research groups within the materials science and the electronics divisions. From 1986 to 1989, he was a postdoctoral research fellow at Caltech, where he performed fundamental studies (cited in the 1999 Nobel Prize in Chemistry) observing the dynamics of unimolecular chemical reactions in real-time.

He received his Bachelor of Science in physics from the California Institute of Technology in 1981, and his Master of Science (1983) and doctorate (1987) in applied and engineering physics from Cornell University.

In 2012, Dr. Rosker was selected as a Fellow of the IEEE for "his leadership in microwave and millimeter-wave phased arrays, gallium nitride semiconductors, and terahertz electronics."

INDUSTRY CONSORTIUM (MIG & MAP)

Agilent Technologies
Analog Devices, Inc.
Applied Materials
Dow
Draper
DSM
Edwards
HARTING

Hitachi High-Technologies
IBM
Lam Research Corp.
NCSOFT
NEC
TSMC
Texas Instruments
Waters

From its very inception, MIT has maintained an intimate connection with industry to inform and inspire its research endeavors. The Microsystems Industrial Group (MIG), established in the early 80s, proved to be an effective platform for engagement of industry with the MTL community! The launch of MIT.nano this past year defines a new chapter in MIT's history for advancing science and technology at the nanoscale. MARC2020 will be co-hosted by MTL and MIT.nano, and we are delighted to have MIT.nano's Member Advisory Panel (MAP) also join us at MARC2020. It is our distinct pleasure to welcome all of our industry partners to MARC.

POSTER SESSIONS

SESSION 1: CIRCUITS: INTEGRATED ELECTRONICS, ENERGY EFFICIENT AI, AND SYSTEMS

1.01	Improvement of Long-Term Stability of CMOS Molecular Clock	1
1.02	Method and Countermeasure for SAR ADC PSA.....	1
1.03	Low Power Fluxgate Magnetometers for Industrial Current Sensing	2
1.04	Low Loss High Current High Frequency Inductor and Test Fixture Design	2
1.05	Reconfigurable CNN Processor for Compressed Networks	3
1.06	DC-DC Converter Implementations Based on Piezoelectric Resonators	3
1.07	Accelergy: An Architecture-Level Energy Estimation Methodology for Accelerator Designs	4
1.08	A Mutual Information Accelerator for Autonomous Robot Exploration	4
1.09	Fast and Energy-Efficient Monocular Depth Estimation on Embedded Platforms	5
1.10	Depth Map Estimation and Compression for Low Power Time-of-Flight Imaging	5
1.11	Flexible Low Power CNN Accelerator for Edge Computing with Weight Tuning	6
1.12	SynCells - Microelectronic Particles for Sensing Applications.....	6
1.13	Vertical Leakage Characteristics of GaN Power Transistors	7
1.14	Impact of Source Resistance on Compensated Networks.....	7

SESSION 2: ENERGY HARVESTING AND STORAGE

2.01	A CMOS-Based Energy Harvesting Approach for Laterally-Arrayed Multi-Bandgap Concentrated Photovoltaic Systems	9
2.02	Silicon MEMS Compatible Micro Rocket Engine Using Steam Injector	9
2.03	Low-Frequency Buckled Beam MEMS Energy Harvester	10
2.04	Height-dependent, surface structure enhanced, intrachip flow boiling of methanol.....	10
2.05	Spray Pyrolysis Deposition and Characterization of Proton-Conducting Ceria for Solid State Glucose Micro Fuel Cells	11
2.06	Optimizing Electrokinetics in Nanopores.....	11
2.07	Understanding the Role of Anti-Reflection Coating and the Metal-Grid Pattern in Silicon Solar Cells.....	12

SESSION 3: ELECTRONIC AND QUANTUM DEVICES 1

3.01	W Contacts to H-Terminated Diamond	15
3.02	GaN Vertical Nanostructures for Field Emission Applications	15
3.03	Alligator Photonic Crystal Cavities in Bulk Diamond	16
3.04	Cavity-Enhanced Emission From Diamond Color Centers for Multiplexed Repeaters.....	16
3.05	Multispectral Spin Clusters for Efficient Multiplexed Quantum Communication	17
3.06	Nonvolatile Control of Long-Distance Spin Transport in an Easy-Plane Antiferromagnetic Insulator.....	17
3.07	Towards Characterizing Magnetic Regimes in 2D RuCl ₃ Kitaev Spin Liquids Using Quantum Sensing.....	18
3.08	Spin-Orbit Torque Switching of Antiferromagnetic Materials	18
3.09	Vertical GaN Fin Transistors for RF Applications.....	19
3.10	Strongly Correlated Physics in Twistronics: Interaction-Driven Exotic States and Phase Transitions in Twisted Bilayer-Bilayer Graphene	19
3.11	Traveling Wave Parametric Amplifiers with High Kinetic Inductance Superconducting Nanowires	20
3.12	Josephson Travelling Wave Photon Detector.....	20
3.13	Cryogenic GaN HEMTs for Application in Quantum Computing Electronics	21

SESSION 4: NANOTECHNOLOGY AND NANOMATERIALS

4.01	Near Field Infrared Nanoscopy and Spectroscopy Study of Novel Van der Waals Low Dimensional Materials	23
4.02	Electron Transparent Anodes for Field Emission Cathodes in Poor Vacuum	23
4.03	AMC: AutoML for Model Compression and Acceleration on Mobile Devices.....	24
4.04	A Thermo-Mechanical Tunnel Mid-Infrared Bolometer	24
4.05	Universal High-Speed Dynamics of Distorted Bubble Skyrmions in an Uncompensated Amorphous Ferrimagnet	25
4.06	Large-Area Multiplexed Graphene Sensors for Detection of Ions in Electrolyte	25
4.07	Bandgap Engineering of Silicon and Diamond for Electronic Applications Through Machine Learning.....	26
4.08	Tunable Perovskite Nanoplatelets with Enhanced Stability for Next-Generation Light-Emitting Technology.....	26
4.09	Morphological Stability of Nanometer-Scale Single-Crystal Metallic Interconnects	27
4.10	Resistless WS ₂ and MoS ₂ Patterning Methods.....	27
4.11	Measurement of the Condensation Coefficient of Water Using an Ultrathin, Nanoporous Membrane.....	28
4.12	Van der Waals Heterostructure Flash Memory for High-Accuracy Neuromorphic Computing.....	28

SESSION 5: MEDICAL DEVICES AND BIOTECHNOLOGY

5.01	Nanoparticle for Drug Delivery Using TERCOM	31
5.02	Measuring Eye Movement Features Using Mobile Devices to Track Neurodegenerative Diseases	31
5.03	Wireless Programmable Optogenetics with Multimodality Integrated Fibers	32
5.04	Nanoscale Solid-State Glucose Fuel Cell for Energy Harvesting in the Human Body.....	32
5.05	Implantable Microphones for Fully Implantable Hearing Prosthetics	33

SESSION 6: ELECTRONIC AND QUANTUM DEVICES 2

6.01	Simulation and Analysis of GaN CMOS Logic.....	35
6.02	Single-Photon Single-Flux Coupled Detectors	35
6.03	Quantitative Study on Current-Induced Effects in an Antiferromagnet Insulator/Pt Bilayer Film.....	36
6.04	Investigation of Dynamic Operation of Negative Capacitance with InGaAs MOSFET in the multi-GHz Regime	36
6.05	Study of Magneto-Excitons in a Tunable Bandgap Semiconductor.....	37
6.06	TCAD Simulations of Vertical Diamond FinFETs for Power Electronics	37
6.07	CMOS Integration of Control Logic for Solid State Spins.....	38
6.08	Degradation under Forward Bias Stress of Normally-Off GaN High Electron Mobility Transistors	38
6.09	Control of Conductive Filaments in Resistive Switching Oxides.....	39
6.10	Quantum Landscape Engineering of Superconducting Circuit Ground States for Higher-Order Coupler Design.....	39
6.11	Surface Spin Induced 1/f Flux Noise Dependent on SQUID Geometry	40
6.12	Novel Synaptic MOSFET by Gate Stack Engineering.....	40
6.13	Novel Gate Technology for High Frequency Transistors.....	41
6.14	Magic-Angle Graphene Superlattices: a New Platform for Strongly Correlated Physics	41

SESSION 7: PHOTONICS AND OPTOELECTRONICS

7.01	Engineering Inter-Landau Level Transitions in Graphene for Tunable THz Optical Devices	43
7.02	Graphene-Loaded Slot Antennas for Multispectral Thermal Imaging	43
7.03	VCSEL-Based QCSE Modulator Arrays for Optical Neural Networks	44
7.04	Hafnia-Filled Photonic Crystal Emitters for Micro-Scale Thermophotovoltaic Energy Generation	44
7.05	A 3-D Integrated Photonics Platform with Deterministic Geometry Control	45
7.06	Optical Neural Networks: Experimental Progress.....	45
7.07	Integrated Liquid-Crystal Devices for Visible-Light Modulation.....	46
7.08	Single-Element, Aberration-Free Fisheye Metalens	46
7.09	Strategies Towards High Performance Solid-State Triplet-Triplet Annihilation Based Photon Upconversion.....	47
7.10	Adjoint-Based Sensitivity Analysis for Silicon Photonic Variations	47
7.11	Integrated-Photonics-Based Holographic Projector for Augmented Reality.....	48

7.12	Amorphous Germanium Waveguides for Evanescent Sensing in the Mid - Longwave Infrared.....	48
7.13	Microfluidic Diffraction Grating Using Fluids of Varied Refractive Indices	49

SESSION 8: MATERIALS AND MANUFACTURING

8.01	Electrostatic Improvement of Sputtered Microstructure.....	51
8.02	Surface Modification of Additively Manufactured Components	51
8.03	Adopting and Characterizing 3D Cell Culture for In vitro Plant Studies	52
8.04	Rapid Uniformity Tuning in Ion Implantation Systems Using Bayesian Optimization.....	52
8.05	High Power Density Dielectric Elastomer Actuators for the Design of Flapping Wing Aerial Robots.....	53
8.06	Spatial-Temporal Graph Neural Networks for Modeling Automated Material Handling System Traffic	53
8.07	3D-Printed, Low-cost, Miniature Liquid Pumps for Compact Systems.....	54
8.08	Low-Cost Protocol to Relate Breakdown Voltage and Vertical Displacement in SiNx-Au Microcantilevers.....	54
8.09	Microfluidic Manufacturing Analysis for Microemulsion Generation	55
8.10	The Effect of Geometry on the Sorting Capabilities of Microfluidic Devices	55
8.11	Formation of J-Aggregates on the Interface in Microfluidics	56
8.12	Delivering In-Plane Light to μ Fluidic Devices For Optical Manipulation.....	56

Session 1: Circuits: Integrated Electronics, Energy Efficient AI, and Systems



Minah Kim
minahkim@mit.edu
Seeking summer internship.
PhD supervised by Ruonan Han.
Available from October 2022.

Research Interests:
Integrated circuits.

Improvement of Long-Term Stability of CMOS Molecular Clock

M. Kim, H. Lee, R. Han
Sponsorship: NSF

1.01

CMOS molecular clocks provide a highly-stable frequency reference by building a negative feedback loop in which a crystal oscillator's frequency is continuously corrected by the molecules' transition frequency. Its fully electronic operation enables the small form factor and low-cost implementation. However, due to the finite loop gain and errors generated from circuits, previous clocks have a limited long-term stability.

In this work, in order to achieve a higher stability regardless of the loop gain, the frequency multiplication factor of a phase-locked loop (PLL) is fine-controlled. Also, the effect of non-linear characteristics of a voltage-controlled oscillator is reduced and baseline calibration is added. The proposed architecture will significantly improve the stability while keeping the cost to a minimum.

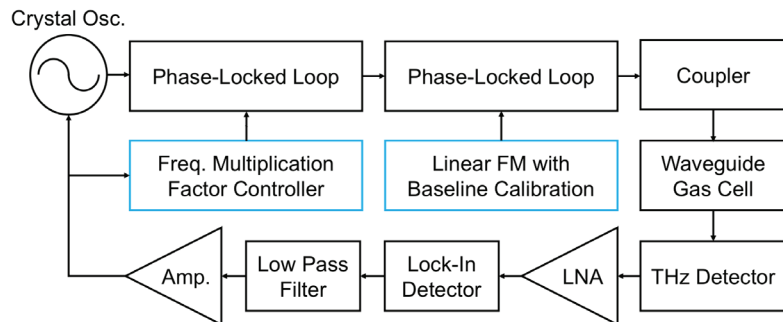

▲ Block diagram of the proposed architecture.



Taehoon Jeong
thjeong@mit.edu
Seeking summer internship.
PhD supervised by Anantha Chandrakasan and Hae-Seung Lee
Available from June 2021.

Research Interests:
Integrated circuits, analog and mixed signal circuit design.

Method and Countermeasure for SAR ADC PSA

T. Jeong, A. P. Chandrakasan, H.-S. Lee
Sponsorship: Analog Devices, MIT CICS, Korea Foundation for Advanced Studies

1.02

Sensors can be deployed in a setting where it acquires private sensor data of their users. To avoid attackers stealing the sensitive data, security must be ensured in all layers of communication including the physical layer. In this context, the power side-channel leakage of an ADC can be an attractive target of attackers as it can easily leak digitized sensor output.

In this work, we propose a SAR ADC power side-channel attack (PSA) method and a countermeasure that protects a SAR ADC from the proposed PSA method. To demonstrate the proposed concepts, we designed and fabricated a 12-bit SAR ADC in 65nm CMOS. Experiments show that the proposed PSA method can reveal A/D conversion results of unprotected SAR ADC with high accuracy, but fails to do so after enabling the proposed protection scheme.

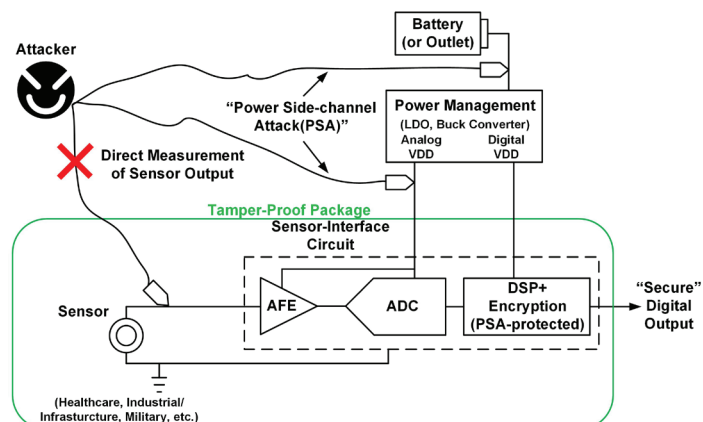

▲ SAR ADC PSA scenario.

Low Power Fluxgate Magnetometers for Industrial Current Sensing

P. Garcha, V. Schaffer, B. Haroun, S. Ramaswamy, J. Weiser, J. Lang,

A. P. Chandrakasan

Sponsorship: Texas Instruments

1.03



Industrial current sensing is important for both power quality management and machine health monitoring. Prof. Lang and Harting offer an industrial solution in the form of smart connectors. They add current sensing abilities to connectors using integrated fluxgate magnetometers, getting rid of large field concentrators, and thereby saving cost, area, and installation effort. However, the integrated fluxgate sensors are power hungry: using ten sensors for a 3-phase current measurement requires up to 1 W of power, which adds up quickly. We offer an improved, bandwidth scalable fluxgate magnetometer with duty cycling, for a more suitable Industrial Internet of Things solution. We use a mixed signal architecture along with quick convergence algorithms and power saving techniques to achieve higher bandwidth, lower energy per measurement, and bandwidth scalability. This work offers the flexibility to make power-bandwidth-noise trade offs and it makes the smart connectors more viable.

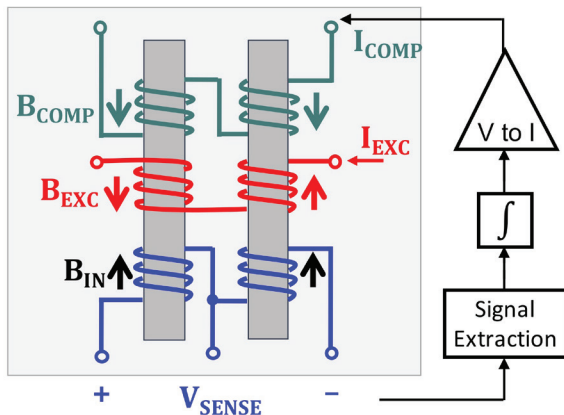

◀ How fluxgate sensing works: the sensor has 2 magnetic cores and 3 coils: excitation, sense, and compensation. When excited, one core saturates before the other, producing voltage V_{SENSE} as a function of $(B_{IN} - B_{COMP})$. Compensation provides linearity.

Preet Garcha

pgarcha@mit.edu

Seeking regular employment.

PhD supervised by Anantha Chandrakasan.

Available from June 2020.

Research Interests:

Electronics, energy harvesting devices and systems, integrated circuits, sensors, systems.

Low-Loss, High Current Inductor and Test Fixture Design

R. Bayliss, R. Yang, A. Hanson, D. J. Perreault

Sponsorship: NSF

1.04



High frequency magnetics are integral to many power electronic systems today: induction heating, wireless power, and RF communication to name a few. Air-core, solenoid inductors are often used due to their ease of design and construction. However due to the proximity effect, current crowds to the center of the inductor creating high loss. Additionally, fringing fields induce eddy currents in surrounding components, requiring physically large boxes to not incur additional losses.

In this work, a distributed gap inductor design utilizes high performance magnetic materials to shape the reluctances of the inductor to reduce or even eliminate the proximity effect and significantly reduce the loss in the inductor. This project is an extension of a lower power proof of concept with a factor of four increase in frequency and factor of 50 increase in energy storage. The second half of this work involves the design of a test fixture to experimentally verify the simulated loss at the operating point of 55 Arms. This project will directly lead to an ~10% increase in overall system efficiency and a dramatic reduction in system's size.

Rod Bayliss III

rodbay@mit.edu

Seeking summer internship.

SB supervised by Dave Perreault.

Available from December 2019.

Research Interests:

Electronic devices, electronics, nanomanufacturing, nanotechnology.

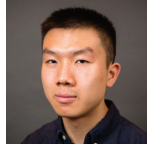

Reconfigurable CNN Processor for Compressed Networks

1.05

A. Ji, W. Jung, K. Sethi, A. P. Chandrakasan

Sponsorship: TSMC

Alex Ji
jjzexi@mit.edu
Seeking summer internship.
PhD supervised by Anantha Chandrakasan.
Available from June 2022.

Research Interests:
Electronics, integrated circuits, systems.

Convolutional neural networks (CNNs) have become the standard for performing complex tasks such as image classification due to their high accuracy. However, they typically involve substantial computation (~109 multiplies and adds) to process a single image and require a large amount of storage (~10 to 100 MB) for the fixed weight parameters and intermediate output activations. This makes it challenging to process CNNs locally on edge devices with low power and low latency. To address this, we need custom hardware accelerators to exploit the high parallelism present in the computations. At the same time, they should be flexible enough to support various networks, especially as new and better networks are continually being developed. Because of the memory constraints on edge devices, we focus on networks compressed by techniques such as Deep Compression and Trained Ternary Quantization, which quantize the weights to a small number of unique values (usually 16 or fewer).

We propose a scalable architecture for efficiently processing compressed networks by reordering the multiplications and additions. Instead of performing each multiply-and-add separately, we accumulate all the activations multiplied by the same weight together and perform the multiplication at the end. With a small number of unique weights, the number of multiplications is greatly reduced, and consequently, the average energy per operation is lowered. To enable the trade off between accuracy and efficiency, we added reconfigurability for different weight and activation bit widths. This allows us to use shorter bit widths in applications where energy must be minimized and a drop in accuracy can be tolerated. With added support for residual connections and depthwise convolutions, our accelerator can run modern networks such as ResNet and MobileNet, enabling CNN processing for a wide range of applications on energy-constrained devices including cell phones and IoT nodes.



DC-DC Converter Implementations Based on Piezoelectric Resonators

1.06

J. D. Boles, J. J. Piel, D. J. Perreault

Sponsorship: Texas Instruments, NSF Graduate Research Fellowship, Masdar Institute

Jessica D. Boles
jboles@mit.edu
Seeking summer internship.
PhD supervised by David Perreault.
Available from June 2021.

Research Interests:
Batteries, electronics, energy, energy harvesting devices and systems, photovoltaics, power management.

Power electronics are vital to the technological progress of major industries such as transportation, energy, and information technology. Demand for power electronics to be smaller volume and lighter weight will eventually require new converter energy storage mechanisms with fundamentally higher density and efficiency limits. This prompts investigation into piezoelectric resonators (PRs), which have very high power densities and efficiencies but have seen little use in power conversion. In this work, we enumerate and evaluate dc-dc converter implementations that utilize a PR as the only energy transfer component, and that maximize efficiency by resonant charging/discharging all circuit capacitances. Experimentally, these converters demonstrate nearly a 10x reduction in loss compared to commercial options. Thus, these PR-based converters are promising alternatives for miniaturized power conversion, especially for applications such as consumer electronics, biomedical implants, and flight.

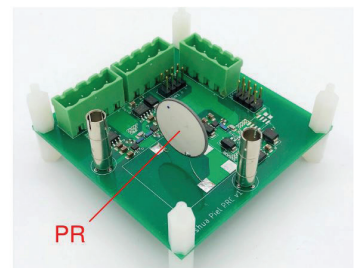
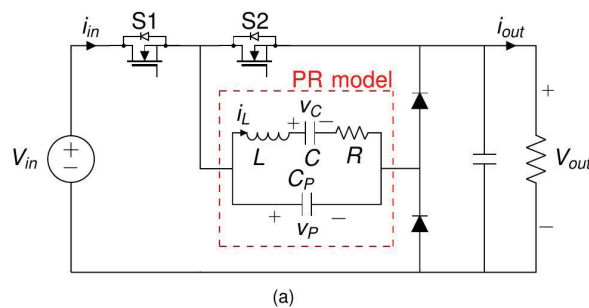

▲ (a) Schematic of one PR-based converter topology, which relies on only the PR for energy storage and has only two active switches. (b) Photograph of a converter prototype corresponding to this schematic.

Accelergy: An Architecture-Level Energy Estimation Methodology for Accelerator Designs

Y. N. Wu, J. S. Emer, V. Sze

Sponsorship: DARPA, MIT Presidential Fellowship, Facebook Faculty Award

1.07



Yannan Nellie Wu
nelliewu@mit.edu
Seeking summer internship.
PhD supervised by Vivienne Sze.
Available from May 2023.

Research Interests:
Energy, multimedia, systems.

With Moore's law slowing down, energy efficient accelerators have become promising for bringing energy efficiency improvements for memory and computation intensive applications (e.g., deep neural networks (DNNs), robotics). To ensure the fast exploration of the accelerator design space, architecture-level energy estimators, which perform estimations without hardware description of the designs, are critical to designers. However, existing energy estimators can't be easily used to generate accurate estimates for accelerator designs, as accelerators are very diverse. We present Accelergy, a generally applicable energy estimation methodology for accelerators that allows architecture description with user-defined compound components and primitive components, which are characterized by third-party estimation plug-ins. Accelergy achieves 95% accuracy on a well-known DNN accelerator. With the validation, we have shown that the flexibility and accuracy of our energy estimation framework.

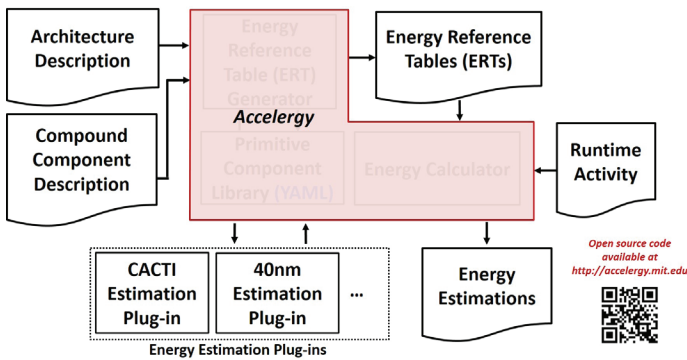

◀ (a) High-level estimation framework. ERTs record the energy/actions (an action is an operation on a component, e.g., read on an SRAM) for each component in the architecture. Energy estimations record the component-wise energy consumption.

A Mutual Information Accelerator for Autonomous Robot Exploration

P. Z. X. Li, K. Gupta, S. Karaman, V. Sze

Sponsorship: AFOSR YIP, NSF

1.08

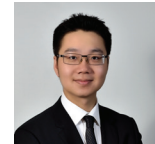

Peter Zhi Xuan Li
peterli@mit.edu
Seeking summer internship.
PhD supervised by Vivienne Sze.
Available from June 2024.

Research Interests:
Electronics, integrated circuits, systems, robotics.

Autonomous exploration is used in search and rescue which requires fast mapping of the unknown environment. To enable fast mapping, the robot computes Shannon's mutual information (MI) for the entire map in order to determine the optimal scan locations that maximally reduce the number of unknown regions in the map. However, MI computation for the entire map is slow (~7s on CPU) and becomes the bottleneck for fast exploration.

We propose a hardware architecture that contains a provably optimal class of memory banking patterns and an arbiter that maximizes memory bandwidth for supporting 16 parallel high-throughput MI cores on an ASIC in TSMC 65nm. Based on our post-layout simulations, the ASIC computes the MI map of size 201x201 in 90ms and consumes 164mW, which leads to fast and optimal selection of exploration trajectories that minimize exploration time and energy. We also prototyped our hardware architecture on an FPGA and integrated the system into a real-time exploration demo.

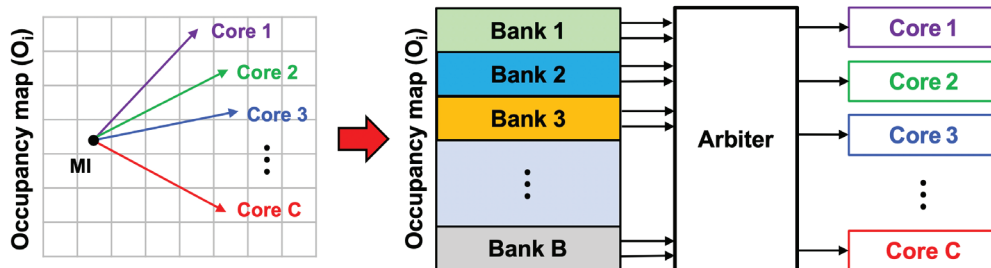

▲ Proposed hardware architecture uses memory banking for partitioning the map storage and an arbiter for efficiently servicing memory requests, which eliminates dual-port SRAM bandwidth limitation and enables parallel operation of 16 MI cores.

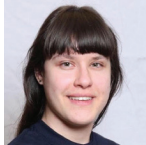

Fast and Energy-Efficient Monocular Depth Estimation on Embedded Platforms

1.09

D. Wofk, S. Karaman, V. Sze

Sponsorship: Intel

Diana Wofk
dwofk@mit.edu
Seeking regular employment.
MEng supervised by Vivienne Sze.
Available from June 2020.

Research Interests:
Information processing, integrated circuits, multimedia, systems.

Depth sensing is a critical function for many robotic tasks such as localization, mapping and obstacle detection. There has been a significant and growing interest in performing depth estimation from monocular RGB camera images, due to the relatively low cost, size, weight and power of cameras. However, state-of-the-art depth estimation algorithms are based on fairly large deep neural networks, which have high computational complexity and energy consumption. This poses a significant challenge when performing real-time depth estimation on an embedded platform, for instance, mounted on a Micro Aerial Vehicle (MAV).

Our work addresses this problem of fast and energy-efficient depth estimation on embedded platforms. Our proposed network, FastDepth, runs at 178 fps on the Jetson TX2 embedded GPU, with active power consumption of 8.8 W. We seek to further improve energy efficiency by deploying onto a low-power embedded FPGA. Using an algorithm-hardware co-design approach, we develop a dataflow design and an accelerator architecture that minimizes off-chip memory accesses and offers dedicated support for depthwise separable convolutional layers.



Depth Map Estimation and Reconstruction for Low Power Time-of-Flight Imaging

1.10

A. Cheng, J. Noraky, V. Sze

Sponsorship: Analog Devices, Inc.

Alan Cheng
adcheng@mit.edu
Seeking regular employment.
MEng supervised by Vivienne Sze.
Available from June 2020.

Mobile augmented reality (AR) technology has seen immense growth in recent years, such as the release of Google Maps Live View, which overlays real-time direction indicators over the camera viewpoint. 3D data is often used in AR applications in order to determine surface normals, allowing for the correct placement of virtual objects in the real-world scene. Time-of-flight (ToF) cameras can be used to acquire this data by emitting light and measuring its round-trip time to measure depth. However, continuous acquisition of high-quality depth maps requires the ToF camera to expend significant amounts of power emitting light, lowering the battery-life of the underlying device. To reduce power consumption, we propose an algorithm that limits the ToF camera usage by simultaneously estimating depth maps and building a scene map.

We exploit the 3D motion calculated across images acquired by a standard camera alongside the ToF camera, which are acquired with much lower power consumption. Additionally, when the ToF camera depth map is needed, we use the depth data to create a scene map. Our algorithm first attempts to estimate the future depth map using the calculated 3D motion. If estimation fails, our algorithm then reconstructs the depth map using the stored scene map. In our approach, the ToF camera is only used when the 3D motion or a reasonable depth map cannot be obtained. We demonstrate the real-time performance of our algorithm using a FPGA-CPU co-processing architecture. We also evaluate our algorithm on both synthetic and real data and show that we can obtain accurate depth maps, demonstrating that our approach is feasible for mobile depth sensing applications.

Flexible Low Power CNN Accelerator for Edge Computing with Weight Tuning

M. Wang, A. P. Chandrakasan

Sponsorship: Foxconn Technology Group

1.11



Miaorong Wang
miaorong@mit.edu
Seeking regular employment.
PhD supervised by Anantha Chandrakasan.
Available from June 2022.

Research Interests:
Integrated circuits, systems.

Smart edge devices that support efficient neural network (NN) processing have recently gained public attention. With algorithm development, previous work has proposed small-footprint NNs achieving high performance in various medium complexity tasks, e.g. speech keyword spotting (KWS), human activity recognition (HAR), etc. Among them, convolutional NNs (CNNs) perform well, which gives rise to the deployment of CNNs on edge devices. A hardware platform for edge devices should be (1) flexible to support various NN structures optimized for different applications; (2) energy efficient to operate within the power budget; (3) achieving high accuracy to minimize spurious triggering of power-hungry downstream processing, since it is often part of a large system.

This work proposes a weight tuning algorithm to improve the energy efficiency by lowering the switching activity. A flexible and runtime-reconfigurable CNN accelerator is co-designed with the algorithm and demonstrated with a feature extraction processor on an FPGA. The system is fully self-contained for small CNNs and speech keyword spotting is shown as an example. A fully integrated custom ASIC is also fabricated for this system. Based on post place-and-route simulation of the ASIC, the weight tuning algorithm reduces the energy consumption of weight delivery and computation by 1.70x and 1.20x respectively with little loss in accuracy.

SynCells - a 60x60 μm Electronic Sensor Platform

M. Hempel, E. McVay, J. Kong, T. Palacios

Sponsorship: Air Force Office of Scientific Research

1.12



Marek Hempel
marekh@mit.edu
Seeking regular employment.
PhD supervised by Jing Kong and Tomás Palacios.
Available from June 2020.

Research Interests:
2D materials, electronics, integrated circuits, nanomanufacturing, nanomaterials, nanotechnology.

Autonomous electronic systems smaller than the diameter of a human hair ($<100 \mu\text{m}$) can enable new applications such as monitoring individual biological cells or embedding them in fibers for smart clothing. However, they are difficult to implement due to fabrication challenges and inadequate energy sources. Here we present SynCells, a $60 \times 60 \mu\text{m}$ electronic platform on an SU-8 substrate that combines molybdenum disulfide sensors and transistors, germanium timers, and magnetic iron pads. These materials are easy to integrate on SU-8 and both the sensor and timer do not require power to measure. In a proof-of-concept experiment, we magnetically positioned SynCells in a microfluidic channel to detect polyamine. After we extracted them from the channel, we successfully read out the timer and sensor signal, the latter of which was amplified by an onboard transistor circuit. In the future, SynCells may be useful in clinical research or even lead to printable/sprayable sensor coatings.

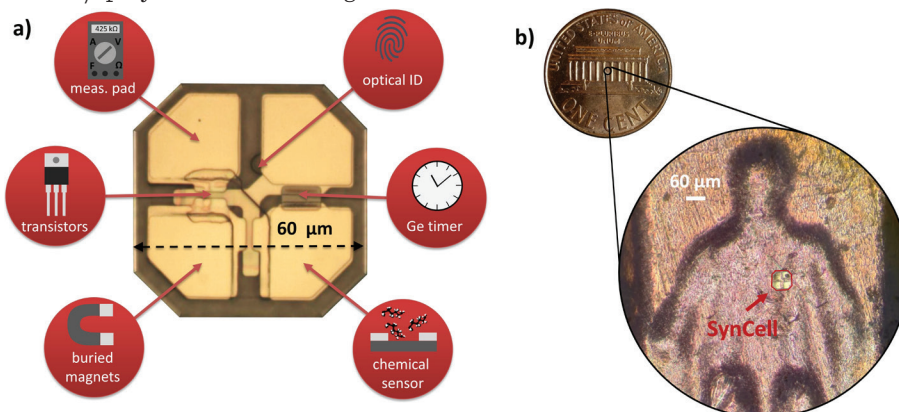

▲ (a) Optical image of a SynCell with its individual building blocks, (b) Size comparison of SynCell on a cent coin.

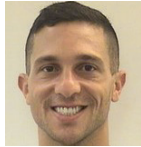

Vertical Leakage Characteristics of GaN Power Transistors

1.13

A. Massuda, J. A. del Alamo

Aviram Massuda
aviram@mit.edu
Seeking regular employment.
PhD supervised by Jesús del Alamo.

Research Interests:
GaN.

The great promise of Gallium Nitride Metal-Insulator-Semiconductor High Electron Mobility Transistors (GaN MIS-HEMTs) in the growing power electronic market has rapidly positioned these devices at the forefront of a new technology wave. This wave has triggered a vast amount of worldwide research and yielded continuous improvement in device performance and electrical reliability. In this regard, the maximum value of the device breakdown voltage is ultimately limited by the vertical breakdown of the drain-body junction. This is particularly a concern for devices with conductive substrates.

A way to mitigate premature drain-body breakdown under high positive drain voltage consists of applying a positive voltage to the body with respect to the source so that the drain-body voltage is reduced. A potentially problematic consequence of this is excessive source-body leakage current under off conditions. This is undesirable. In this work, we study the source-body leakage in commercial prototype devices for negative source bias with respect to the body. Figure 1 shows the body current as the source is swept negative and then positive at 26 °C. The different paths that are followed could be due to a trapping or a floating-body effect. Figure 2 shows temperature dependence of the negative sweep. The sharp corner in the characteristics that coincides with the maximum widening of the “eye” opening under positive and negative sweeps follows an Arrhenius equation with an activation energy of -0.13eV. These and other interesting features are critical to understanding the origin of the reverse bias source-body current so that it can be suppressed.

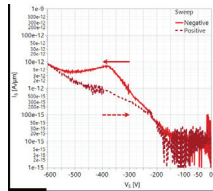

▲ Figure 1: I-V characteristics between source contact and Si substrate. During the measurement, the drain and gate terminal are floating, the Si substrate is kept at 0 V and the source is swept down from 0 V to -600 V (solid line) and then back to 0 V (dashed line).

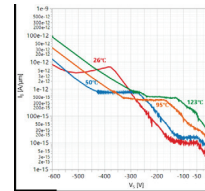

▲ Figure 2: Temperature dependence of the negative sweep I-V characteristics between source contact and Si substrate. During the measurements, the drain and gate terminal are floating, the Si substrate is kept at 0 V and the source is swept down from 0 V to -600 V.



Impact of Source Resistance on Compensated Networks

1.14

D. E. Schemmel, C. M. Cooke

Sponsorship: Prolec GE

Daniel Ervin Schemmel
dschemme@mit.edu
Seeking summer internship.
PhD supervised by Chathan Cooke.
Available from May 2022.

Research Interests:
Wireless power transfer, energy harvesting, RF circuits and systems, power electronics, signal processing, radar, phased array antennas.

In wireless power applications, it is a common practice to include a compensation network that enhances the voltage and current characteristics at the transmitter and receiver terminals. For magnetic resonant wireless power systems in particular, the compensation network typically provides the means for resonance and is implemented by the addition of reactive components to the input and output terminals of a loosely coupled transformer. When designed correctly, compensation can reduce the burden on the drive electronics by enabling zero-voltage switching and input zero phase angle (ZPA). The compensation network can also be designed to allow for a constant-voltage output (CVO) or constant-current output (CCO) with respect to load. This invariance to load not only serves to broaden the available applications of the wireless power system, but also reduces the complexity of the control and corresponding circuitry. The four most common compensation topologies used to obtain the aforementioned characteristics include the series-series (SS), series-parallel (SP), parallel-series (PS), and parallel-parallel (PP) compensation networks, which are all implemented with the addition of a single capacitor at the input and output of the transformer.

Since the most prolific application of compensation is for inductive wireless power transfer, most of the theory for compensation is tailored to the compensation of transformers. In contrast, our research focuses on the compensation for arbitrary linear two-port networks with the condition that they are lossless and reciprocal. Analysis is performed for each of the four fundamental compensation topologies in order to obtain CCO or CVO performance along with simultaneous input ZPA. Although most of the compensation literature assumes the use of ideal sources and lossless components, our research also aims to quantize the effects of finite source resistance on the desired compensation performance.

Session 2: Energy Harvesting and Storage

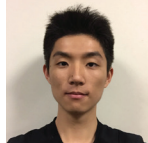

Haoquan Zhang
haoquan@mit.edu
Seeking summer internship.
PhD supervised by David Perreault.
Available from September 2022.

Research Interests:
Electronics, energy, integrated circuits, power management.

A CMOS-Based Energy Harvesting Approach for Laterally-Arrayed Multi-Bandgap Concentrated Photovoltaic Systems

H. Zhang, K. Martynov, D. J. Perreault

Sponsorship: ARPA-E

2.01

In applications where high solar conversion efficiency are desired, people often adopt concentrated photovoltaic systems with multi-junction cells. Traditional tandem structures widely used in such systems can suffer from current-mismatch effects with spectrum variations, while the Laterally-Arrayed Multi-Bandgap (LAMB) cell structure is a potentially higher-efficiency and lower-cost alternative.

Here we show an energy harvesting approach for LAMB cells. Individual cells within a sub-module block are connected for approximate voltage-matching, and a Multi-Input Single-Output (MISO) buck converter combines the energy and performs Maximum Power Point Tracking locally. A miniaturized MISO dc-dc converter prototype is developed in a 130nm CMOS process. For 45-160mW power levels, >95% peak efficiency is achieved in a small form factor designed to fit within available space in a LAMB cell block. The results demonstrate the potential of the LAMB CPV system for enhanced solar energy capture.

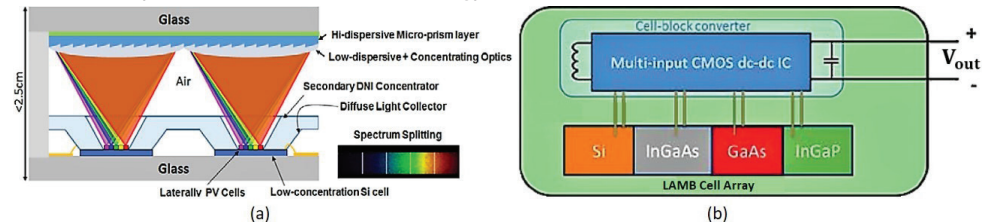

▲ (a) Structure of a LAMB cell unit. An optical layer spectrally-splits and focuses direct sunlight onto multi-bandgap III-V cells, and a Si cell collects diffuse light. (b) Die photo with annotations, with 1.3mm by 1.7mm chip area.



Jonathan Protz
jprotz@mit.edu

Silicon MEMS Compatible Bipropellant Micro Rocket Engine using Steam Injector

J. Protz

Sponsorship: Protz Lab Group; microEngine, LLC; Asteria Propulsion, LLC

2.02

Micro-fabricated miniature chemical rocket engines have been an active area of research at MIT and elsewhere for two decades; they are a compelling propulsion option for small launch vehicles and spacecraft. As originally proposed by the PI, miniaturized steam injectors like those used in Victorian-era steam locomotives are viable as a pumping mechanism at these scales and offer an alternative to pressure-feed or high-speed turbo-pumps. Previously, the PI and his group built and tested ultraminiature-machined micro jet injectors that pumped ethanol and also explored liquid and hybrid engine designs. Recent work has focused on designing and implementing a whole-engine test article that simultaneously integrates a steam injector, boiler, decomposition chamber, fuel injector and thrust chamber, that is practical to build, and that is compatible with 2D MEMS fabrication. An axisymmetric engineering mockup in brass was built to demonstrate the feasibility of the design concept.

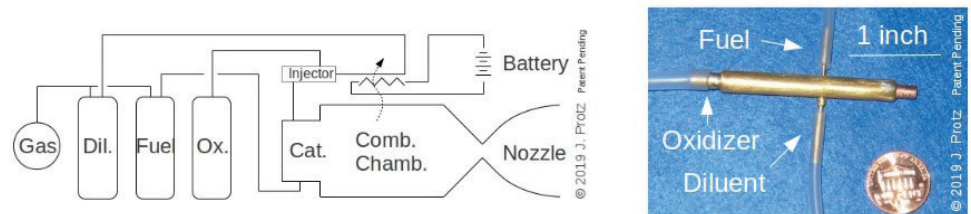

▲ (a) Schematic representation of engine and (b) engineering mock-up in brass of a fully-integrated engine.

Low-Frequency Buckled Beam MEMS Energy Harvester

R. Xu, H. Akay, S.-G. Kim

Sponsorship: MIT-SUTD International Design Center

2.03



Haluk Akay
haluk@mit.edu

Seeking regular employment.
PhD supervised by Sang-Gook Kim.
Available from June 2022.

Research Interests:

Energy harvesting devices and systems, MEMS and NEMS, systems, MEMS product design, machine learning.

Vibrational energy harvesting at the MEMS scale is a unique challenge for low-frequency sources which are ubiquitous but do not operate at resonant frequencies of structures on the micro scale. It is nature's law that resonant frequency is inversely proportional to mass, which is a great challenge for micro-scale energy harvesting devices operating at low frequencies (less than 100Hz). A bi-stable buckled beam design is presented that does not rely on resonance of a MEMS structure but rather operates by snapping between buckled states at low frequencies. A fully functional piezoelectric MEMS energy harvester is designed, monolithically fabricated, and tested. Dynamic testing, however, demonstrated that optimizing the beam stiffness to proof mass ratio was challenging given the presence of undesired modes of vibration. This iteration of the design demonstrates how changes to the proof mass geometry can enhance the dynamic performance of the device.

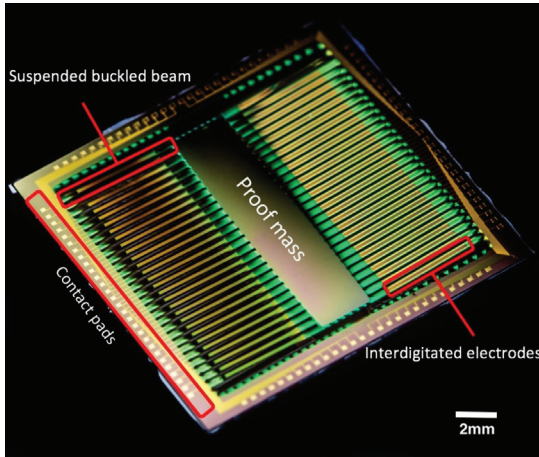

◀ (a) Photograph of released energy harvesting device.

Height-Dependent, Surface Structure Enhanced, Intrachip Flow Boiling of Methanol

J. D. Sircar, Y. Zhu, S. R. Rao, E. N. Wang

Sponsorship: Office of Naval Research

2.04



Jay D. Sircar
jsircar@mit.edu

Seeking regular employment.
PhD supervised by Evelyn Wang.
Available from February 2020.

Research Interests:

Electronic devices, energy, energy harvesting devices and systems, integrated circuits, MEMS and NEMS, nanomanufacturing, nanotechnology, power management, si, thermal structures, devices and systems.

Microchannel flow boiling is capable of meeting the thermal management requirements of high heat flux in integrated circuits, but it is limited by instabilities. Using boiling water, surface microstructures have been shown to suppress instabilities and enhance the critical heat flux (CHF) and heat transfer coefficient (HTC). In subzero °C environments, water is not an ideal heat transfer fluid. Methanol is a potential working fluid for devices that might cycle through such low temperatures. Here we show thermal hydraulic enhancement from surface microstructures on flow boiling of methanol. We fabricated semiconductor devices that have single microchannel etched into their silicon handle, with and without micropillars. Thermal performance enhancement from microstructures was found in both the CHF, 42% increase to 911 W/cm², and in the HTC, 74% increase to 320 W/cm² K. Flow boiling of methanol in microstructured channels offers a promising cooling strategy for challenging environments.

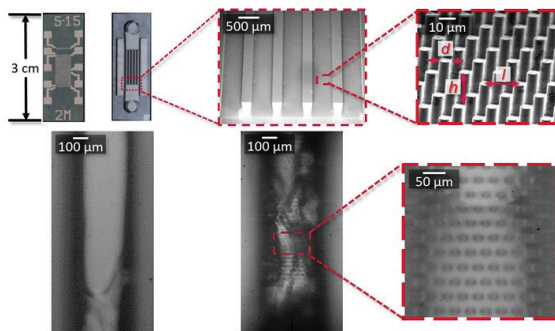

▲ Optical images of the (a) front and (b) backside of a tested device. (c & d) SEM micrograph cross section of a tall micropillar structured multi-channel device. Optical images of the flow boiling taken in a (e) smooth and (f & g) structured channel.



Kierstin Torres
 kierstin@mit.edu
 Seeking summer internship.
 SB supervised by Jennifer Rupp.
 Available from June 2022.

Research Interests:
 Batteries, electronic devices,
 energy, fuel cells, nanomaterials,
 nanotechnology.

Spray Pyrolysis Deposition and Characterization of Proton-Conducting Ceria for Solid State Glucose Micro Fuel Cells

K. P. Torres, P. Simons, J. L. M. Rupp

Sponsorship: Undergraduate Research Opportunities Program

2.05

Implantable solid state glucose fuel cells are promising candidates for powering medical implants, given their ability to harvest energy from glucose and oxygen within the human body. In particular, they can operate as a perpetual power source, making them advantageous to conventional batteries that need to be replaced relatively frequently. Ceria is an advantageous electrolyte given that it is biocompatible, can be deposited at a thickness of a few hundred nanometers, and can conduct protons via an adsorbed surface water layer at lower temperatures and moist atmospheres. This project focuses on a novel, abiotic glucose fuel cell composed of a free-standing ceria electrolyte membrane and porous platinum electrodes.

In this work, we explore the deposition of ceria proton conducting electrolyte films through spray pyrolysis. Spray pyrolysis was chosen as the ceria deposition method because of its low cost and scalability, since it does not rely on high vacuum as chemical and physical vapor deposition methods. Ceria thin films were deposited onto silicon nitride coated silicon substrates at various processing conditions. Air spraying pressure, deposition duration, and annealing temperatures were major processing factors that affected film quality and structure.

Electrochemical Impedance Spectroscopy was carried out on sprayed ceria thin films with an in-plane electrode architecture in moist and dry atmospheres. In agreement with literature, it was found that under moist air at temperatures below 100°C, conductivity increased with decreasing temperatures. Samples under dry air exhibited no measurable ionic conductivity at lowered temperatures. This reconfirms that at lower temperatures, proton conduction occurs in an adsorbed water layer. We succeeded to produce proton conducting, dense ceria thin films with controlled grain size which is a start point to deposit free-standing electrolyte films.

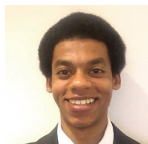

Nathanael Assefa
 assefa@mit.edu
 Seeking regular employment.
 Available from June 2020.

Research Interests:
 Biological devices and systems,
 bioMEMS, microfluidic devices and
 systems.

Optimizing Electrokinetics in Nanopores

N. Assefa, P. de Souza, M. Bazant

Sponsorship: MIT SuperUROP

2.06

The most underutilized renewable energy generation approach, reverse electrodialysis, is capable of powering 15% of global power with minimal infrastructure investment and 99% efficiency. Previous nanopore lithography limitations that had constrained efficiency to 10% have been lifted by angstrom length pore designs with unknown and unoptimized physical properties.

In this work we optimize these angstrom length nanopore designs for energy conversion efficiency and ion separation using a generalized electro kinetic solver by considering non-linear differential equations coupling charge transport, chemical potential gradients and fluid flow. We demonstrate order of magnitude increases in the theoretical efficiency of membrane based reverse electrodialysis for energy harvesting, near 100% for optimal pore designs.

We also explore the relative impact of design deficiencies on charge transport within a pore and overall effectiveness along asymmetries in radius, concentration, and pH present in real world applications both due to manufacturing and environmental factors.

Understanding the Role of Anti-reflection Coating and the Metal-grid Pattern in Silicon Solar Cells

S. Yadav, J. Scholvin

2.07



Shubham Yadav
shyadav@mit.edu

Silicon solar cells have been investigated for their superior lifetimes and high efficiencies for several decades. Researchers have tried to optimize parameters like device thickness, carrier-mobility, recombination life-time, antireflective coating (ARC), and metal-grids to make highly efficient devices. People have also tried out a combination of ARC coatings including single-layer, bilayers made out of oxides, nitrides and other materials. Further, they have also optimized the metal-grids to obtain an equilibrium based on resistive losses and shading losses. This paper will focus on learning the effects of the bi-layer ARC and metal-grids on the device efficiency. Two ARC designs were considered along with different combinations of metal-grid to understand the optical losses and charge collection process at the top surface. Devices with efficiencies up to 11.7% were made with an improvement of more than 90% when compared to the unoptimized devices made during the same process.

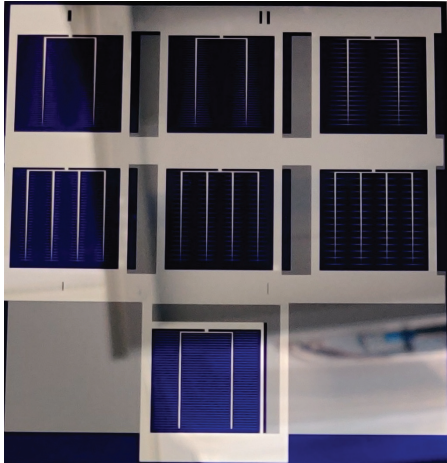

◀ Solar cells fabricated with different combinations of metal-grids are shown. The first two rows have tapered metal-grids with variations in the width of metal-fingers and the last row contains a device with rectangular metal-grid.

Session 3: Electronic and Quantum Devices 1



Alon Vardi
 alonva@mit.edu
 Seeking summer internship.
 Research scientist supervised by
 Jesús del Alamo.
 Available from November 2020.

Research Interests:
 2D materials, biological devices
 and systems, electronic devices,
 electronics, energy, field-emitter
 devices, GaN, III-Vs.

W Contacts to H-terminated Diamond

A. Vardi, M. Tordjman, R. Kalish, J. A. del Alamo
 Sponsorship: Bose, DARPA

3.01

Diamond is a leading candidate for harsh environment high-power electronics due to their extraordinary thermal and electrical properties. One of the many challenges facing diamond electronics is creating reliable and stable ohmic contacts to hydrogen-terminated diamond (D:H). In this work we explored a novel approach for scalable and self-aligned ohmic contacts to D:H.

The diamond surface conductivity is governed by its termination. H-termination (D:H) is conductive while O-termination (D:O) is insulating. The different terminations are typically obtained by exposing the diamond surface to H or O plasma. In D:H all the dangling bonds are practically passivated, it therefore suffers from poor adhesion to most materials which are only weakly attached by Van der Waals forces. D:O however, can provide good adhesion. In our approach we pattern W contacts on D:O providing good adhesion. After this, the diamond surface is exposed to the H plasma. We use W since it can withstand the H-plasma step. State-of-the-art results for contact and sheet resistance are obtained shown in (c).

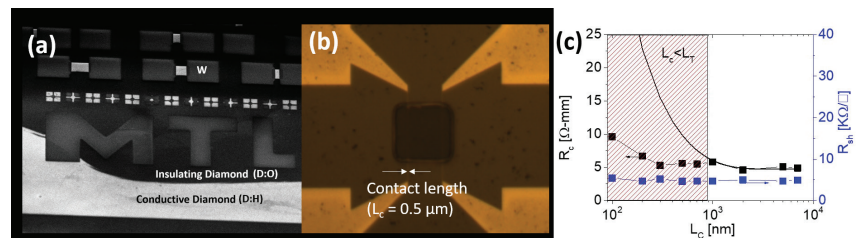

▲ (a) SEM of Diamond test structure. Black is D:O, white is D:H. (b) Four terminals nanocontact TLM test structure. (c) Contact resistance (black markers, left scale) and D:H sheet resistance (blue markers, right scale).



Pao-Chuan Shih
 pcshih@mit.edu
 Seeking summer internship.
 PhD supervised by Tomas Palacios.
 Available from August 2024.

Research Interests:
 2D materials, electronic devices,
 electronics, energy harvesting
 devices and systems, field-emitter
 devices, GaN, III-Vs.

GaN Vertical Nanostructures for Field Emission Applications

P.-C. Shih, G. Rughoobur, A. I. Akinwande, T. Palacios
 Sponsorship: MURI/AFOSR

3.02

Field emitters, or namely vacuum transistors, are promising for harsh-environment and high-frequency electronics thanks to their radiation-hard and scattering-free vacuum channels. However, operation voltage, stability, and circuit integration of these devices are still important challenges. To overcome these issues, III-Nitrides are proposed as suitable candidates because of their strong bonding energies and tunable electron affinities, which are beneficial for stable and low-voltage operation, respectively. In this work, we demonstrate some preliminary results of GaN vertical fins and nanowires via a top-down approach. With vertical nanostructures, a self-aligned process for gate and integrated anode is also proposed aiming for scalable circuit integration. With this technology developed, polarization engineering and AlGaIn alloys could also be utilized in the future to further reduce the electron affinity and enable the use of these devices in logic and high-frequency applications.

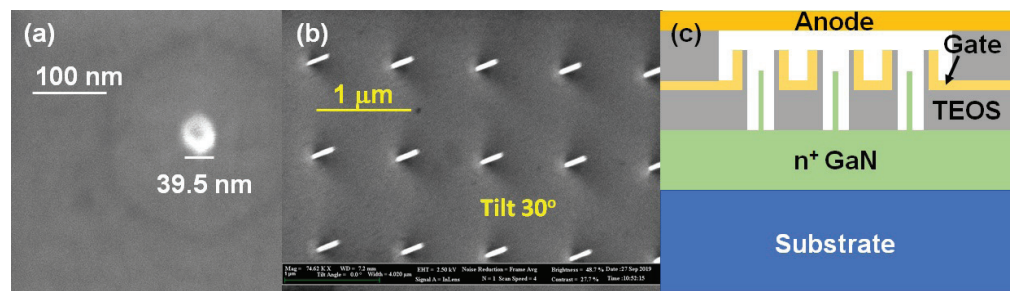

▲ (a) Top-view and (b) 30° tilted SEM images of GaN NWs and (c) a proposed structure with an integrated anode

Alligator Photonic Crystal Cavities in Bulk Diamond

K. C. Chen, E. Bersin, S. Mouradian, D. Englund

Sponsorship: NSF, U.S. Army Research Laboratory

3.03

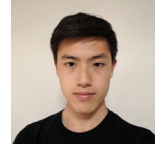

Kevin C. Chen

kcchen@mit.edu

Seeking summer internship.

PhD supervised by Dirk Englund.

Research Interests:

Information processing,
nanotechnology, photonics,
quantum devices.

Cavity-Enhanced Emission From Diamond Color Centers for Multiplexed Repeaters

M. Sutula, K. Chen, D. Englund

Sponsorship: MIT EECS Alan L. McWhorter Fellowship, NSF, MIT Lincoln Laboratory

3.04



Madison Sutula

mmsutula@mit.edu

Seeking summer internship.

PhD supervised by Dirk Englund.

Research Interests:

Electronic devices, electronics,
nanotechnology, optoelectronics,
photonics, quantum devices,
sensors, spintronics.

Quantum networks will require scalable quantum information processing architectures for fast data rates and reliable communication. Recently, the first memory-enhanced quantum repeater that beats direct photon transmission between two communication nodes was realized. However, achieving the range and speed demanded by proposed quantum applications on the quantum internet requires quantum repeater nodes with many multiplexed memory qubits. In particular, it is necessary to optically excite and measure many color centers fast and efficiently. We will present progress on multiplexed repeaters based on color centers in diamond, with a particular focus on fabrication of diamond waveguides for enhanced collection efficiency.



Eric Bersin
 ebersin@mit.edu
 Seeking regular employment.
 SM supervised Dirk Englund
 Available from May 2021.

Research Interests:
 2D materials, communications,
 electronic devices, information
 processing, integrated circuits,
 nanotechnology, photonics,
 quantum devices, sensors,
 spintronics.

Multispectral Spin Clusters for Efficient Multiplexed Quantum Communication

E. Bersin, K. Chen, M. Trusheim, D. Englund

Sponsorship: NASA, U.S. Department of Defense, NSF, Siebel Foundation

3.05

Solid-state defect centers have emerged as a promising platform for quantum communication due to their long coherence times, coherent optical interface, and potential for on-chip integration. In particular, the nitrogen vacancy (NV) and silicon vacancy (SiV) centers in diamond have shown great promise, with demonstrations of on-demand entanglement generation, quantum key distribution that breaks the repeaterless bound, and scalable integration onto mature photonic platforms. To scale up from these proof-of-principle demonstrations, we propose the use of multispectral registers, where multiple defect centers operating at different optical frequencies occupy a single optical volume. We study various regimes for such clusters, propose a protocol for their use, and examine pathways towards experimental realization of such a system. In particular, we show that such a system could dramatically improve fidelity and rate in quantum networking applications, allowing realization of scalable quantum key distribution, distributed quantum computation, and quantum-enhanced large baseline interferometry.

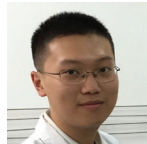

Jiahao Han
 jhhan@mit.edu
 Seeking summer internship.
 PhD supervised by Luqiao Liu.
 Available from June 2022.

Research Interests:
 Electronic devices, spintronics,
 magnetism.

Nonvolatile Control of Long-Distance Spin Transport in an Easy-Plane Antiferromagnetic Insulator

J. Han, P. Zhang, Y. Fan, T. S. Safi, J. Xiang, R. Cheng, L. Liu

Sponsorship: NSF, NIST

3.06

How an antiferromagnet transmits spin angular momentum by the quanta of spin-wave excitations, viz. magnons is one of the core topics of antiferromagnetic magnon spintronics. It is generally believed that only easy-axis antiferromagnets can support spin transmission, a natural inference of the fact that the circularly polarized magnons there have finite spin angular momentum. In contrast, easy-plane antiferromagnets would destroy spin transport due to the vanished angular momentum carried by their linearly polarized magnons.

In this work we show that contrary to this traditional picture, spin transmission over micrometer distance indeed happens in an easy-plane insulating antiferromagnet, α -Fe₂O₃ thin film. A model involving superposition of linearly polarized propagating magnons is proposed to account for the observations. Enabled by this physical insight, our work opens up additional possibilities for nonvolatile, low magnetic field control of spin transmission, where a spin-current switch with a 100% on/off ratio is realized.

Towards Characterizing Magnetic Regimes in 2D RuCl₃ Kitaev Spin Liquids using Quantum Sensing

S. Muschinske, D. Englund

Sponsorship: NASA Space Technology Research Fellowship, ARO MURI

3.07



Sarah Muschinske
muschins@mit.edu

Seeking summer internship.

PhD supervised by Dirk Englund.

Available from June 2023.

Research Interests:

2D materials, electronic devices, photonics, quantum devices, spintronics.

α -RuCl₃, a known quantum spin liquid (QSL), exhibits topologically-ordered long-range entanglement making it of great interest for applications in quantum information. Atomically thin layers of α -RuCl₃ are of particular significance as the 2D system is exactly solvable in the Kitaev QSL formalism, however, the majority of experiments on α -RuCl₃ have been performed on the bulk material. Bulk α -RuCl₃ is known to exhibit Kitaev paramagnetic behavior from 6.5-140K, while being conventionally paramagnetic above 140K. However, in a purely 2D system, the material is not expected to exhibit this transition from Kitaev to conventional paramagnetism, potentially extending the temperature range in which the material's exotic behavior is present. In this work, we use nitrogen-vacancy centers in diamond (NVs) to directly probe the magnetic susceptibility using magnetic field varying electron spin resonance at temperatures from liquid He to room temperature. We then compare our measurements to theoretical predictions, as well as previous inelastic neutron scattering measurements of bulk crystals. This characterization will answer questions about the temperature dependence of purely 2D QSL behavior, and will inform the design of future experiments looking to probe QSL physics.

Spin-Orbit Torque Switching of Antiferromagnetic Materials

J. Finley, P. Zhang, Y. Fan, L. Liu

Sponsorship: NSF-SRC

3.08

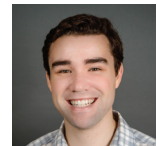

Joseph Finley
jfinley@mit.edu

Seeking regular employment.

PhD supervised by Marc Baldo and

Luqiao Liu.

Available from June 2020.

Research Interests:

2D materials, electronic devices, nanotechnology, spintronics.

Today, information storage using magnetic materials is achieved by controlling the magnetic moment orientation of a ferromagnet. Recently, however, there has been a growing interest to store data in antiferromagnetically coupled materials. Compared with ferromagnetic materials, antiferromagnetic materials have higher magnetic resonant frequencies, potentially allowing them to switch at much higher speeds. Furthermore, antiferromagnetic materials possess no stray field and are stable against external magnetic fields, which would allow them to be a highly scalable and secure information storage medium. Although antiferromagnetic materials possess these ideal qualities, the reading and writing of the antiferromagnetic state has previously been a difficult challenge.

One major hurdle of an antiferromagnetic memory was recently addressed when it was demonstrated an electrical current within an antiferromagnet could switch the Neel vector by 90 degrees. To gain a better understanding of the switching we have grown Mn₂Au thin films on MgO (111) substrates with low (< 1 nm) roughness. Next, we patterned the films into Hall bar devices and applied a series of pulse trains that induce 90 degree switching, which is measured by the planar Hall effect. At large current densities we see much larger changes in the transverse resistance and we even see the switching change directions when the pulse current density is near the device breakdown limit. In order to investigate if the switching is magnetic or a resistance change due to device damage, we also measured the second harmonic longitudinal resistance and found that there is reversible switching within a range of current densities. Based on these results, further studies are needed to exclude non-magnetic resistive effects to accurately determine the magnitude of magnetic switching.



Vertical GaN Fin Transistors for RF Applications

J. Perozek, T. Palacios

Sponsorship: DARPA DREaM, ARPA-E SWITCHES

3.09

Joshua Perozek
jperozek@mit.edu

Seeking summer internship.

PhD supervised by Tomas Palacios.

Available from May 2022.

Research Interests:

Electronic devices, electronics, energy, GaN, III-Vs, nanotechnology.

Wireless data usage is growing at an exponential rate. To meet users' relentless demands for faster data and 5G service, cellular providers must find additional bandwidth within an already cramped RF spectrum, forcing them to use available bands at higher frequencies. Unfortunately, at high frequencies, current transistor amplifiers struggle to meet the linearity and efficiency required for reliable, low-cost wireless systems.

In this work, we present the first vertical GaN fin transistors for RF applications. These devices utilize a scalable fin design that avoids the expensive bulk-GaN substrates or low-quality p-GaN regrowth that has hindered the widespread adoption of GaN electronics. The vertical, multi-fin structure enables a compact device with exceptionally high current densities, enhanced thermal management, and easy integration of linearity-boosting design techniques. Initial results show GaN vertical fin transistors are a promising candidate for next-generation internet.

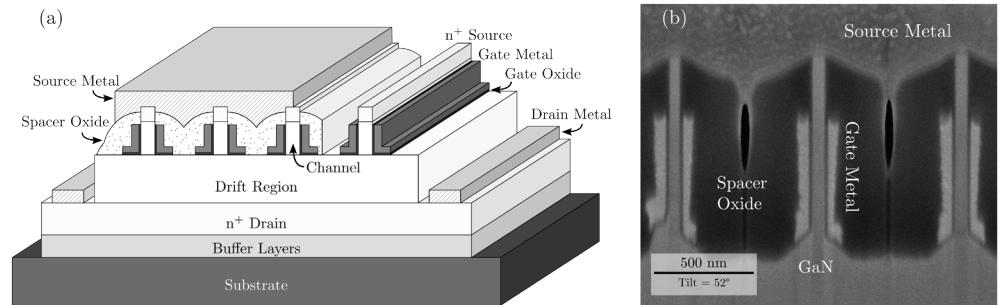

▲ (a) Schematic of the vertical RF fin transistor (not to scale) and (b) SEM cross-sectional image of the fabricated device.



Strongly Correlated Physics in Twistronics: Interaction-Driven Exotic States and Phase Transitions in Twisted Bilayer-Bilayer Graphene

J. M. Park, Y. Cao, D. Rodan-Legrain, O. Rubies-Bigorda, P. Jarillo-Herrero

Sponsorship: U.S. Department of Energy, NSF Center for Integrated Quantum Materials, Gordon and Betty Moore Foundation

3.10

Jeong Min Park
parkjane@mit.edu

Seeking regular employment.

PhD supervised by Pablo Jarillo-Herrero.

Available from September 2024.

Research Interests:

2D materials, quantum devices.

Strong correlations between electrons in quantum materials give rise to exotic states and phase transitions, and allow unconventional material properties. Investigating the origin and nature of these interaction-driven phenomena has been of great interest for physicists for both fundamental theoretical understanding and possible role in nanotechnology. Recently, another platform for studying such physics, called "twistronics," has gained tremendous attention after the discovery of unconventional superconductivity and correlated insulator states in magic-angle twisted-bilayer graphene (MATBG) superlattices. When two sheets of monolayer graphene are twisted by a small angle around 1.1° , known as the magic-angle, a nearly flat band forms, in which Coulomb interaction of electrons dominates over the kinetic energy. In this strong-correlation regime, insulating states that are absent in the single-particle band structure appear, and superconductivity is observed. The exact mechanisms for these phenomena are still greatly unknown, and numerous follow-up works are being done in MATBG systems and other twisted superlattices. Here, we construct another twistronic system with bilayer graphene to investigate the strongly correlated physics. This twisted bilayer-bilayer system exhibits extra tunability of correlated states with electric field, and displays further transitions upon magnetic field. Electrically tunable exotic insulating states and spin-polarized magnetic phase transitions will be presented. This work will provide new insights into understanding the rich physics in strongly correlated systems, as well as novel device applications in the future.

Traveling Wave Parametric Amplifiers with High Kinetic Inductance Superconducting Nanowires

K. Peng, M. Colangelo, D. Zhu, K. K. Berggren, K. P. O'Brien

3.11

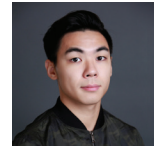

Resonantly phase matched Josephson traveling wave parametric amplifiers (JTWPAs) with several gigahertz of bandwidth enable simultaneous readout of potentially more than 20 frequency multiplexed qubits and are now broadly used in superconducting quantum computing. However, their fabrication is challenging, requiring thousands of few percent uniform Josephson junctions, and is not compatible with the superconducting qubit fabrication process. We propose to realize nanowire traveling wave parametric amplifiers (nTWPAs) with comparable gain, bandwidth, and noise performance. The nonlinearity of the high kinetic inductance niobium nitride nanowires are used instead of Josephson junctions to realize wave mixing, and aluminum oxide deposited by atomic layer deposition is used to implement the low loss capacitors. The fabrication process of nTWPAs therefore becomes compatible with the qubit fabrication. Furthermore, the high kinetic inductance of nanowires provides higher tolerance to ambient magnetic fields and decouples linear inductance from nonlinearity, which in turn provides more design freedom and simplifies the scaling of device dynamic range.

Kaidong Peng
kdpeng@mit.edu

Seeking summer internship.
SM supervised by Kevin P. O'Brien.
Available from May 2020.

Research Interests:

Quantum devices, superconducting qubits, quantum acoustics, quantum optics.

Josephson Travelling Wave Photon Detector

Y. Ye, K. Peng, M. Naghiloo, K. O'Brien

Sponsorship: MIT EECS Jin Au Kong Fellowship

3.12

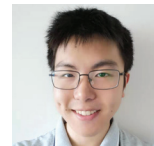

A single photon detector capable of high-fidelity and wide bandwidth detection of microwave photons has remained elusive and impedes the progress of many quantum technologies. Here, we investigate a new Josephson Travelling Wave Photon Detector with the promise of >99% fidelity non-destructive detection of microwave photons over a wide ~GHz bandwidth. The broadband detection relies on non-linear interactions between a wide band-pass signal transmission line and a probe transmission line. Single photons propagating in the signal line will induce a photon-number dependent phase shift on a large number of co-propagating photons in the probe transmission line. By measuring the induced phase shift on the probe photons, we can deduce the photon number of interest with high fidelity. This high-performance single microwave photon detector will complete the missing piece in existing quantum hardware systems and thus enable the next generation of quantum technologies.

Yufeng Ye
brightye@mit.edu

Seeking summer internship.
PhD supervised by Kevin P. O'Brien.
Available from June 2024.

Research Interests:

Electronic devices, information processing, integrated circuits, photonics, quantum devices.



Qingyun Xie
qyxie@mit.edu
Seeking summer internship.
PhD supervised by Tomas Palacios.
Available from June 2023.

Research Interests:
2D materials, actuators,
communications, electronic
devices, electronics, energy
harvesting devices and systems,
GaN, III-Vs, integrated circuits,
medical devices and systems.

Cryogenic GaN HEMTs for Application in Quantum Computing Electronics 3.13

Q. Xie, N. Chowdhury, A. Zubair, J. Lemettinen, I. Charaev, K. K. Berggren,

T. Palacios

Sponsorship: IBM

In order to realize robust quantum information systems operating below 4 K, high performance and scalable cryogenic electronic devices are essential components. Current electronics rely on technologies like CMOS (Si), or heterojunction bipolar transistors (e.g. SiGe, InP).

This work explores the use of wide band gap heterostructures at cryogenic temperatures – specifically, the AlGaIn/GaN high electron mobility transistor (HEMT). These structures take advantage of the polarization-induced two-dimensional electron gas to create a high mobility channel, thus eliminating the use of heavy doping as in other technologies. MOCVD-grown GaN-on-Si is available in 8-inch and even 12-inch substrates. Furthermore, the use of superconducting electrodes is proposed to significantly reduce the parasitic components and, therefore, push the RF performance of cryogenic devices. The interaction between superconductor material and the heterostructure will be studied. Eventually, it is hoped that these devices will be integrated into low noise amplifier circuits for applications in readout and control electronics at cryogenic temperatures.

Session 4: Nanotechnology and Nanomaterials



Matthew Yeung
myeung@mit.edu
Seeking summer internship.
PhD supervised by Long Ju.
Available from May 2025.

Research Interests:

2D materials, electronic devices, electronics, energy, energy harvesting devices and systems, lasers, nanomaterials, nanotechnology.

Near Field Infrared Nanoscopy and Spectroscopy Study of Van der Waals Low Dimensional Materials

M. Yeung, T. Han, Q. Zhang, L. Ju

Sponsorship: NSF Center for Integrated Quantum Materials, MIT Hewlett-Packard Fellowship, NSF Graduate Research Fellowship Program

4.01

The past decade has witnessed the birth and rapid development of two-dimensional materials and their heterostructures. Recently, progresses in material synthesis enabled research on low-dimensional materials, such as Metal-Organic Frameworks, nanowires, and transition metal nitrides. These non-conventional material systems offer exciting opportunities for both fundamental physics study and device applications due to their versatility in crystal structure. Here we utilized the near field infrared nanoscopy and spectroscopy techniques to characterize the basic electronic and optical properties with a nanometer spatial resolution. I will show our data on the chemical bonding and structure of these materials and discuss its implications for material synthesis and further characterizations. The data will provide insight on the material and allow us to determine what other methods we should use to probe the material further.

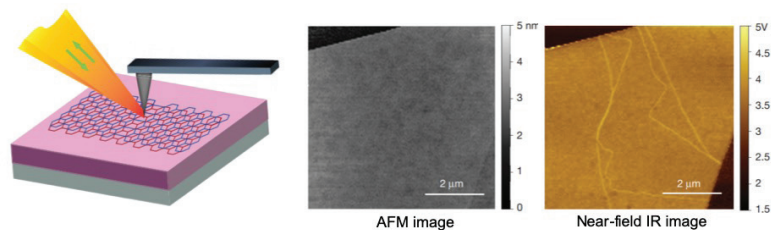

▲ Near field infrared nanoscopy combines the nanometer spatial resolution of Atomic Force Microscopy and infrared light to provide spatially resolved optical conductivity information of materials. Shown are domain walls in graphene.



Girish Rughoobur
grughoob@mit.edu
Seeking regular employment.
Postdoctoral associate supervised by Akinwande I. Akinwande.

Research Interests:

Electronic devices, electronics, field-emitter devices, MEMS and NEMS, nanomaterials, nanotechnology, sensors.

Electron Transparent Anodes for Field Emission Cathodes in Poor Vacuum

G. Rughoobur, L. Jain, A. I. Akinwande

Sponsorship: DARPA/MTO INVEST

4.02

Field emission are ideal replacement for thermionic sources as they have instant response and have lower operating temperature. Silicon field emitter arrays (FEAs) with an integrated gate have demonstrated high-output current density ($\sim 100 \text{ A/cm}^2$) and lifetime exceeding 100 hours under continuous operation. However, the need for an ultra-high vacuum environment (UHV) have limited their use to research applications solely. Barrier height variations induced by adsorption/desorption of gas molecules in poor vacuum cause significant variations in output current due to its exponential dependence on the barrier potential. Furthermore, poor vacuum environment results in back-ion bombardment that causes tip erosion. We are working on thin electron transparent structures (monolayer or multi-layers graphene) suspended on a low-stress nitride membrane to separate the field emission process from less pristine environments. We have demonstrated electron transparent of around 20% with a multi-layered graphene. This device could be also be used for “vacuum-less” electron sources.

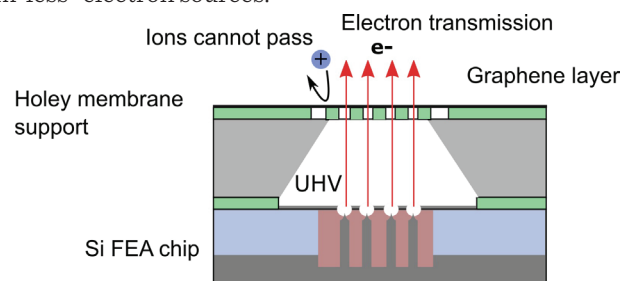

▲ (a) Structure of electron transparent Si FEA with graphene membrane. (b) I-V characteristics of anode current with different grid voltage. (c) Anode current ratio/electron transmission comparison.

AMC: AutoML for Model Compression and Acceleration on Mobile Devices 4.03

N. Emond, B. Yildiz

Sponsorship: Fonds de Recherche du Québec - Nature et Technologies (FRQNT)

Resistive switching (RS) random access memories are considered as possible artificial synapses in next-generation neuromorphic networks, mostly due to their predicted high memory density, energy efficiency and scalability. Integration of these devices in a neuromorphic computing system could allow solving intensive computing tasks actually only handled by the human brains such as speech and character recognition as well as grammar and noise modeling. Within their architecture, redox-based RS memory devices store binary code information using the electric field-induced resistance change of an oxide layer by conductive filament (CF) formation and rupture. Nevertheless, a lack of control on the properties of CFs, which mainly forms at chemical and structural defects, causes detrimental cycle-to-cycle and device-to-device variations. We are therefore studying the effect of strain on the microstructure, chemistry and RS properties of TiO_2 thin films to get insights into defects formation with the objective of selectively doping along these defects. We found that the microstructural properties of pulsed laser deposited epitaxial TiO_2 films depend on both the film thickness and the nature of the bottom electrode, suggesting a potential method to better control defects properties and improve consistency in RS.

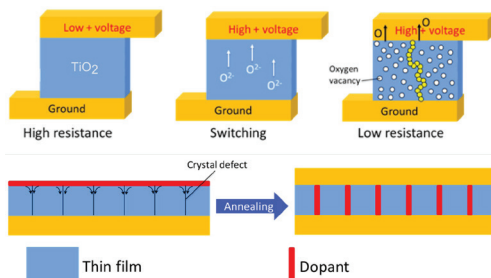

▲ (a) Resistive switching mechanism in a TiO_2 thin film by formation of conductive filaments and (b) its control by selective doping at microstructural defects

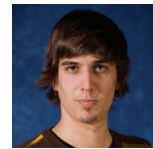

Nicolas Emond
emondn@mit.edu

Seeking regular employment.
Postdoctoral associate supervised
by Bilge Yildiz.
Available from August 2020.

Research Interests:

Electronic devices, nanomaterials,
nanotechnology.

A Thermo-Mechanical Tunnel Mid-Infrared Bolometer 4.04

Y. Lin, E. McVay, J. Han, M. Hempel, J. Kong, J. Lang, F. Niroui, T. Palacios

Sponsorship: ARO MIT-ISN, AFOSR MURI

Uncooled mid-infrared (mid-IR) sensing are highly desired for night vision, security surveillance, remote sensing, industrial inspection, medical and environmental chemical sensing, etc. An essential and challenging step to “invent” any sensitive sensor is to find a material that has some signal transducing mechanism with a very sharp transition. In this work, we demonstrated an extremely sensitive bolometric mid-IR detector based on a suspended metal/molecule/metal nanogap. The tunneling resistance across such a 1nm-sized gap can be tuned by several orders of magnitude through a sub-angstrom-scale displacement applied by an IR-excited thermal actuator. The schematic and SEM images of our proposed device structure are presented in Figure (a). The IR photocurrent mapping (10.6 μm wavelength) of the device are shown in Figure (b). Our theoretical and experimental results suggested that our thermo-mechanical tunnel bolometer can potentially outperform the state-of-the-art uncooled mid-IR detection technologies.



Cosmi Lin
liny@mit.edu

Seeking regular employment.
PhD supervised Tomás Palacios.

Research Interests:

2D materials, actuators,
electronic devices, electronics,
energy, MEMS and NEMS,
nanomanufacturing,
nanomaterials, nanotechnology.

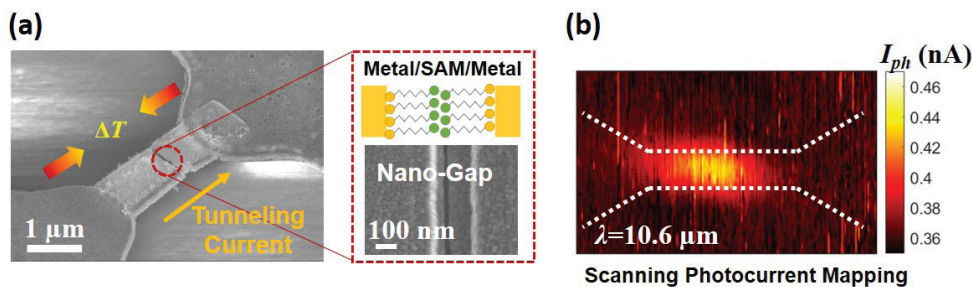

▲ (a) SEM images, schematics and (b) Mid-IR photocurrent response of the thermo-mechanical tunnel bolometer.



Kai Litzius
 litzius@mit.edu
 Seeking regular employment.
 Postdoctoral associate supervised
 by Geoff Beach.
 Available from May 2020.

Research Interests:
 Electronic devices, electronics,
 information processing,
 lasers, nanomanufacturing,
 nanomaterials, nanotechnology,
 spintronics.

Universal High-Speed Dynamics of Distorted Bubble Skyrmions in an Uncompensated Amorphous Ferrimagnet

4.05

F. Büttner, K. Litzius, A. Wittmann, W. Zhou, C. Ting Ma, J. Gräfe, N. A. Träger, S. Finizio, D. Suzuki, S. Huang, L. Caretta, M. Huang, Y. Quessab, H. T. Nembach, G. A. Riley, J. M. Shaw, A. D. Kent, G. Schütz, S. J. Poon, G. S. D. Beach
 Sponsorship: DARPA TEE Program

Magnetic skyrmions are topologically stabilized spin configurations that, like domain walls (DWs), can react to external stimuli by collective displacement, which is both physically intriguing and bears promises to realize next generation non-volatile data storage technologies.

Analytical equations of motion describe straight 180° DWs in the one-dimensional (1D) model while rigid, circular bubble domains and skyrmions move according to the Thiele equation. However, DWs and skyrmions are often not perfectly straight or circular.

Here, we study how strongly deformed DWs and bubble skyrmions move in uncompensated ferrimagnetic Pt/CoGd/W in response to current pulses. We find that all 1D spin textures exhibit velocity saturation at ~300 m/s in agreement with the 1D model, while all fully enclosed spin textures, even if significantly distorted, reach >500 m/s. We attribute this significant difference in the dynamics to the topology and the canting of spins in the skyrmion's encircling DWs.

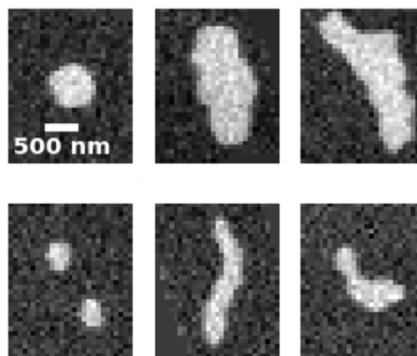

◀ (a) - (f) Examples of analyzed distorted bubbles. All displayed structures are enclosed domains and are therefore topologically equivalent to a skyrmion. Their individual dynamics can be quite different but the ensemble average exhibits skyrmion-like behavior. The scalebar in (a) is the same for all subfigures.



Mantian Xue
 mxue@mit.edu
 Seeking summer internship.
 PhD supervised by Tomás Palacios.
 Available from May 2022.

Research Interests:
 2D materials, electronic devices,
 medical devices and systems,
 nanotechnology, sensors.

Large-area Multiplexed Graphene Sensors for Detection of Ions in Electrolyte

4.06

M. Xue, C. Markin, Y. Luo, T. Palacios
 Sponsorship: MIT-ARL ISN, NSF Center for Integrated Quantum Materials

Graphene is an excellent candidate for next generation sensing platform thanks to its unique electrical, optical, mechanical and chemical properties. Its all-surface structure gives it high sensitivity to the environment. However, it also makes graphene-based devices very sensitive to fabrication process. Small differences in graphene quality can lead to large variation in device behavior. In this work, we developed a novel sensor platform that can simultaneously measure over 200 graphene-based multiplexed sensors to characterize the concentration of sodium, calcium and potassium ions in electrolyte. The system can detect ion concentration spanning over several orders of magnitude with high sensitivity, excellent selectivity, high reversibility and fast response time. By collecting data from a statistically significant sample size, this work presents a manufacturable and reliable technology that can be employed for a wide range of physiologic monitoring applications.

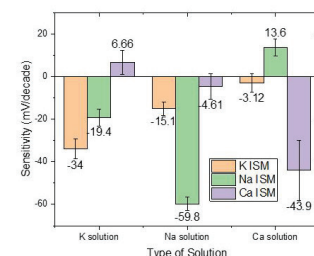
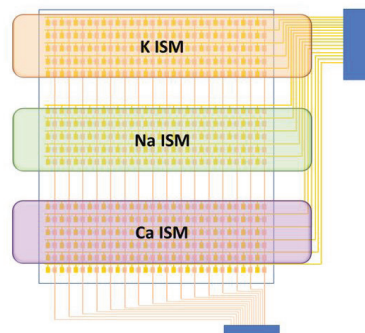

▲ (a) Schematic of the sensor array. (b) Sensitivities and selectivity towards solutions containing K⁺, Na⁺ and Ca²⁺ ions.

Bandgap Engineering of Silicon and Diamond for Electronic Applications Through Machine Learning

Z. Shi, E. Tsybalov, M. Dao, S. Suresh, A. Shapeev, J. Li

4.07



Zhe Shi
shizhe1@mit.edu
Seeking summer internship.
PhD supervised by Ju Li.
Available from June 2021.

Deforming a material to a large extent without inelastic relaxation can result in unprecedented properties. However, the optimal deformation state is buried within the vast continua of choices available in the strain space. Here we advance a unique and powerful strategy to circumvent conventional trial-and-error methods and adopt machine learning techniques for rationally designing the most energy-efficient pathway to achieve a desirable material property such as the electronic bandgap. This method invokes recent advances in the field of artificial neural network by utilizing a limited amount of *ab initio* data for the training of a surrogate model, predicting electronic bandgap within an accuracy of 8 meV. Our model is capable of discovering the indirect-to-direct bandgap transition and semiconductor-to-metal transition in silicon by scanning the entire strain space. It is also able to identify the most energy-efficient strain pathways that would transform diamond from an ultrawide-bandgap material to a narrow-bandgap semiconductor. A broad framework is presented to tailor any target figure of merit by recourse to deep elastic strain engineering and machine learning for a variety of applications in microelectronics, optoelectronics, photonics, and energy technologies.

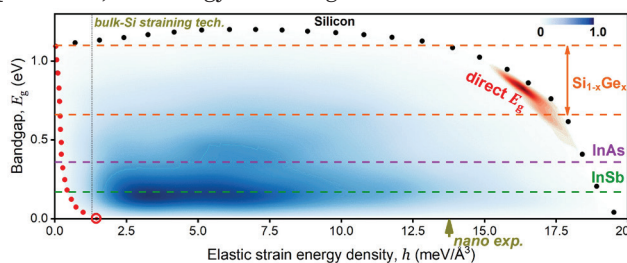

▲ Reachable bandgap values for various elastic strain energy density (h) within the whole deformation space for silicon. The region where the strained silicon has a direct bandgap is colored in red. The circle at $h = 1.35$ meV/Å³ indicates the lowest energy penalty for the semiconductor-to-metal transition.

Tunable Perovskite Nanoplatelets with Enhanced Stability for Next-Generation Light-Emitting Technology

S. K. Ha, W. A. Tisdale

Sponsorship: U.S. Department of Energy

4.08



Seung Kyun Ha
skha89@mit.edu
Seeking regular employment.
PhD supervised by William Tisdale.
Available from December 2020.

Colloidal lead halide perovskite nanocrystals are considered to be highly promising next-generation light-emitting materials due to their solution-processability, high color purity, tunability and bright emission. Especially, strongly quantum- and dielectric-confined two-dimensional colloidal lead halide perovskite nanoplatelets is one of the most favorable candidates.

In this work, we demonstrate the facile synthesis of colloidal perovskite nanoplatelet (Chemical formula: $L_2[ABX_3]_{n-1}BX_4$, L: alkylammonium, A: methylammonium or formamidinium, B: lead, X: bromide and iodide, n: number of $[BX_6]^{4-}$ octahedral layers in the direction of nanoplatelet thickness) at room-temperature via ligand-assisted reprecipitation method. Using the same technique, we show that the band gap of the material can be tuned continuously by changing halide composition. We further demonstrate that we can incorporate various organic species as surface-capping ligands, which highlights the possibility of fine-tuning the nanoplatelet surface properties. Then among various nanoplatelet species, we focus on the deep-blue luminescent ($\lambda_{max} = 437$ nm) nanoplatelets and develop strategies to improve their photostability. It is shown that photobleaching results from intrinsic instability of the nanoplatelet lattice, and moisture facilitates the transformation of nanoplatelets into thicker, more bulk-like structures. We also demonstrate that methylammonium-based nanoplatelets are more stable than formamidinium-based ones, presumably due to the structural robustness. Furthermore, addition of excess alkylammonium bromide ligands is shown to be an effective strategy to enhance the stability of the nanoplatelets. Lastly, we demonstrate stable deep-blue luminescence with high color purity from the dropcasted nanoplatelet film, and discuss the viability of fabricating high-quality light-emitting diode based on those nanoplatelets.

Research Interests:
2D materials, displays, light-emitting diodes, nanomaterials, nanotechnology, optoelectronics



Maxwell L'Etoile
mletoile@mit.edu

Seeking summer internship.

PhD supervised by Carl Thompson.

Available from May 2021.

Research Interests:

Electronic devices, MEMS and NEMS, nanomanufacturing, nanomaterials, nanotechnology, morphological evolution.

Morphological Stability of Nanometer-scale Single-crystal Metallic Interconnects

4.09

M. A. L'Etoile, Y.A. Shin, S. Ezzat, K. R. Coffey, C. V. Thompson

Sponsorship: IBM, QI, SONY, Intel, Samsung, Xilinx, Qualcomm, ARM, AMD, Amazon

Continued IC scaling requires interconnects with cross-sectional dimensions in the <10nm range. At these dimensions the resistance of interconnects increases dramatically due to surface and grain boundary electron scattering. The reliability of interconnects with nanoscale dimensions is also expected to be compromised by reduced morphological stability. As a part of a collaborative program focused on ballistic conduction and morphological stability of single-crystal nanometer-scale interconnects, we are investigating the crystallographic dependence of the morphological stability of Ru and Co wires.

Thin single-crystal films agglomerate into small particles via capillary driven surface diffusion in a process known as solid-state "dewetting." With decreasing film thickness, the temperature at which dewetting occurs is well below the constituent materials melting temperature. However, previous work on single-crystal Ni films has demonstrated that crystalline anisotropy gives rise to special crystallographic orientations along which single-crystal wires are kinetically stable. Interconnects composed of such wires should have decreased vulnerability to morphological instabilities during processing and circuit operation. These wires will have strongly faceted surfaces which are predicted to reduce electron scattering and decrease interconnect resistance. Ru is a candidate material for future interconnects, and exploratory work with single-crystal (0001) films suggests that wires oriented along <1120> directions will be particularly stable. Work on patterning and testing of such wires is currently underway. We have begun similar experiments with single-crystal (0001) Co films. Like ruthenium, Co has a hexagonal close packed crystal structure. Combining new data from these materials with results from past work on Ni, which has a face centered cubic structure, will provide insights that will enable optimization of interconnect structural and crystallographic factors for design of morphologically stable nanowires with cross-sectional dimensions significantly below 10nm.



Jian-An Ke
jakemse@mit.edu

Seeking regular employment.

PhD supervised by Silvija Gradečak

Available from August 2020.

Research Interests:

2D materials, electronic devices, electronics ,integrated circuits, nanomanufacturing, nanomaterials, nanotechnology, photovoltaics, Si.

Resistless WS₂ and MoS₂ Patterning Methods

4.10

J. Ke, K. Bogaert, S. Gradečak

Sponsorship: SMART and the National Research Foundation, Singapore and Top University Strategic Alliance fellowship (TUSA, Taiwan)

Two-dimensional (2D) materials such as graphene and transition metal dichalcogenides (TMDs) exhibit many interesting properties that make them promising materials for novel electronic and optical applications. The application space could be further broadened by having the ability to combine these materials into more complex heterostructures. Conventional patterning methods rely on coating a polymer-based resist that is then exposed (by light or electron beam), developed, and selectively removed. Each of these steps adds to the process complexity, and in the case of 2D materials, potential materials damage. A resistless patterning technique is therefore desirable, due to fewer potentially damaging processing steps, which naturally improves yield and is more cost-efficient.

In this work, we demonstrate two distinct direct-write patterning methods for 2D TMD heterostructures grown by chemical vapor deposition (CVD). The first approach is based on laser-induced method for controlling the location of MoS₂ nucleation within patterned WS₂. We investigate WS₂ defect formation as a function of the laser power and wavelength and demonstrate the site selectivity of subsequent MoS₂ growth. In an effort to push the patterning resolution, the second resistless technique uses electron beam to directly pattern MoS₂ on Si/SiO₂ substrates. By exposing the substrate with an electron beam, we show that CVD-grown MoS₂ preferentially nucleates at the exposed patterns. We will discuss the underlying mechanisms that govern both patterning methods, properties of the resulting TMD materials, resolution limits, as well as the application for more complex TMD heterostructures. These direct-write techniques will simplify the process of heterostructure patterning and enable the routine fabrication of complex device architectures.

Measurement of the Condensation Coefficient of Water Using an Ultrathin, Nanoporous Membrane

G. Vaartstra, Z. Lu, J. Lee, J. C. Grossman, E. N. Wang

Sponsorship: NSF

4.11



Geoffrey Vaartstra
gvaartst@mit.edu
Seeking regular employment.
PhD supervised by Evelyn Wang.
Available from May 2023.

Research Interests:
Energy, nanotechnology, thermal structures, devices and systems.

In applications ranging from electronics cooling and power generation cycles to distillation, liquid-vapor phase change phenomena play a critical role. At their fundamental (kinetic) limits, evaporation and condensation are dictated by the resistance to molecules crossing the liquid-vapor interface, which is quantified by the condensation coefficient. Despite its fundamental importance and widespread use in heat transfer models, the condensation coefficient of water has been difficult to characterize, with experimental results and theoretical calculations spanning three orders of magnitude. To achieve a precise measurement of the condensation coefficient of water, we have fabricated an ultrathin (~200 nm), nanoporous (~150 nm diameter), hydrophobic membrane for forward-osmosis (FO) driven transport. These experimental measurements of the condensation coefficient of water are crucial for modeling liquid-vapor phase change in nanoscale systems and advanced thermal management devices.

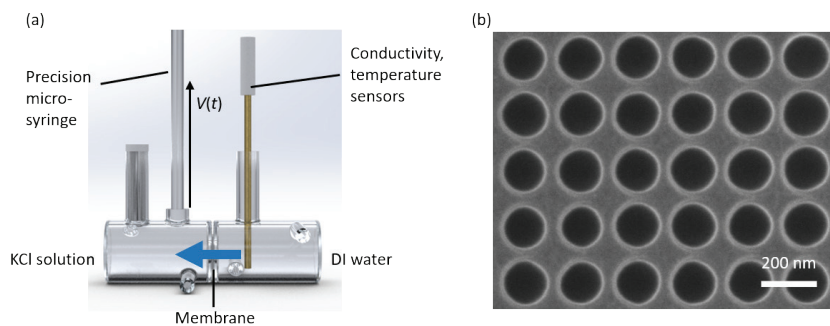

▲ (a) Schematic of the FO experiment. The blue arrow indicates the flux of water vapor across the hydrophobic membrane, which is measured by the volume change $V(t)$ of liquid in the precision syringe. (b) SEM image of the nanoporous membrane.

Van der Waals Heterostructure Flash Memory for High-Accuracy Neuromorphic Computing

J. Zhu, A. Zubair, T. Palacios

Sponsorship: AFOSR FATE MURI

4.12



Jiadi Zhu
jdzhu@mit.edu
Seeking summer internship.
PhD supervised by Tomas Palacios.
Available from May 2025.

Research Interests:
2D materials, electronic devices, energy harvesting devices and systems, GaN, III-Vs, nanomaterials, nanotechnology, SiGe and Ge.

Hardware accelerators based on neuromorphic computing have attracted great attention in recent years, and can potentially overcome the Von Neumann Bottleneck in conventional computing. Novel non-volatile memory (NVM) devices like resistive random access memory, phase change memory, ferroelectric FETs, electrochemical random access memory have shown promise for resolving neuromorphic computing tasks, e.g. pattern recognition and possess good potential to be integrated in accelerator level. However, most of these NVM devices suffer from non-linearity or asymmetry which reduces classification accuracy. Moreover, the electrochemical devices are not CMOS compatible and unstable in ambient environment.

In this work, we propose a novel flash memory that uses a van der Waals heterostructure of atomically thin layered two-dimensional floating gate and semiconductor channel. Contrary to conventional neuromorphic devices, the electrons in the channel can tunnel into the floating layer and get stored inside, where they can linearly modulate the channel conductance and function as a multi-state memory. Such device structure offers the potential for better uniformity, robustness and possesses improved linearity of conductance modulation compared to existing neuromorphic devices. The proposed devices can enable high-accuracy neuromorphic computing, and pave the way for large-scale integration of neuromorphic devices.

Session 5: Medical Devices and Biotechnology



Jonathan M. Protz
jmprutz@mit.edu

Silicon MEMS Compatible Bipropellant Micro Rocket Engine using Steam Injector

J. M. Protz

Sponsorship: Protz Lab Group, BioMolecular Nanodevices LLC

5.01

Targeted drug delivery has been an area of active investigation for many decades. Some approaches target cell-borne receptors; others use external stimuli such as heat or radio waves to drive spatially-localized release. In this work, particles estimate their own location within the body by correlating their sensed fluid environment (e.g. temp., press., salinity, sugar, pH, etc.) against an embodied map and release on the basis of this estimate; the approach is related to terrain contour matching (TERCOM), a technique used in air navigation. As envisioned, a mixture of drug-laden and empty permeable vessels, each with a different environmental response, interconnect through a capacitive volume separated from the surroundings by a permeable film. Using item response theory, the mixture's composition is tailored to deliver a larger dose to preferred capillaries. The work builds on a past effort by the PI and his group to develop nanoparticles which record their experience in DNA.

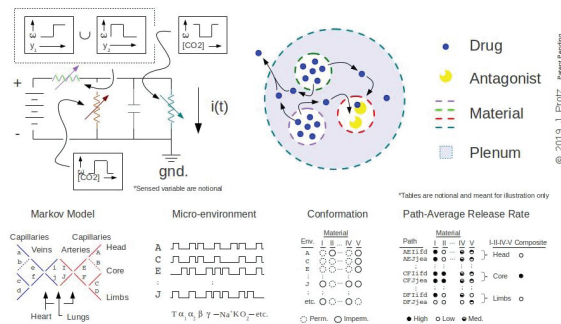

◀ Illustration of concept.



Gladynel Saavedra-Pena
gladynel@mit.edu
Seeking summer internship.
PhD supervised by Vivienne Sze and Thomas Heldt.
Available from July 2022.

Measuring Eye Movement Features using Mobile Devices to Track Neurodegenerative Diseases

G.Saavedra-Pena, H.Y. Lai, C. Sodini, T. Heldt, V. Sze
Sponsorship: MIT Quest for Intelligence (SenseTime)

5.02

Research Interests:
Biological devices and systems, medical devices and systems, multimedia, computer vision, signal processing.

Current clinical assessment of neurodegenerative disease progression (e.g., Alzheimer's disease) is qualitative and time-consuming. These characteristics limit our ability to evaluate treatment response and hinder the development of effective therapies. Eye-movement features have been shown to be significantly different between patients and healthy subjects, suggesting their use as objective, and easily-accessible metrics. However, these features are commonly measured with high-speed, IR-illuminated cameras. A flexible measurement system is required to track them longitudinally. Previously, we showed we can accurately measure visual reaction time using iPhone cameras. We have since developed an app to facilitate data collection and measured more features. With a large amount of data, we can validate the effect of age on these features and identify confounding factors, leading to a better understanding of relationship between eye movement features and disease progression.

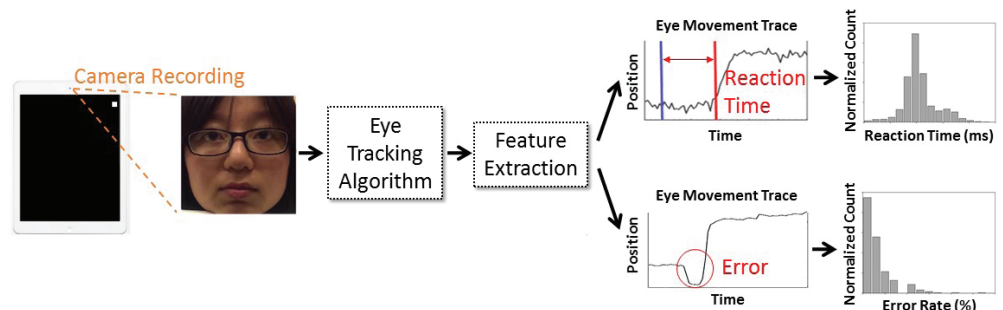

▲ Here, we present an app to make data collection accessible. From the data, our system extracts reaction time and error rates.

Wireless Programmable Optogenetics with Multimodality Integrated Fibers

5.03

A. Sahasrabudhe, S. Orguc, T. Khudiyev, T. Tanaka, M. Antonini, J. Park, A. Canales, Y. Fink, A. Chandrakasan, P. Anikeeva



Atharva Sahasrabudhe
atharva@mit.edu

Seeking regular employment.

PhD supervised by Polina Anikeeva.

Available from May 2022.

Research Interests:

2D materials, actuators, biological devices and systems, electronic devices, energy harvesting devices and systems, light-emitting diodes, MEMS and NEMS.

Reliable operation of neural probes over time scales ranging from minutes to years is essential for longitudinal studies of brain development, aging, and chronic neurological diseases. Recently developed fiber-based neural probes offer a promising platform for integrating multiple functions in a miniature and flexible form factor that is also biocompatible with soft neural tissue.

The traditional approach to light delivery into the brain for optogenetics studies relies on tethering implanted fibers to external sources via optical cables. This limits the range of possible experiments, particularly those involving complex motor functions or social interactions among multiple animals. Moreover, the fibers also incorporate conducting electrodes that enable chronic extracellular electrophysiology and microfluidic channels for delivery of drugs and genes to the target neural tissue, while still maintaining a miniature device footprint ($\sim 270 \times 200 \mu\text{m}$). A custom made flexible and modular transponder enables wireless operation and offers digital programmability across a wide range of control parameters such as frequency, duty cycle, light intensity and independent device addressability, thereby permitting straightforward and robust application of these probes in a multitude of behavioral assays.

Nanoscale Solid-State Glucose Fuel Cell for Energy Harvesting in the Human Body

5.04

P. Simons, M. A. Gysel, S. A. Schenk, K. P. Torres, J. L. M. Rupp

Sponsorship: Merck KGaA, Darmstadt, Germany; Broshy Graduate Fellowship; Hugh Hampton Young Fellowship



Philipp Simons
psimons@mit.edu

Seeking regular employment.

PhD supervised by Jennifer Rupp.

Available from June 2020.

Research Interests:

Batteries, biological devices and systems, bioMEMS, energy, energy harvesting devices and systems, fuel cells, medical devices and systems, nanomanufacturing, nanomaterials, nanotechnology.

Efficiently powering the next generation of highly miniaturized bio-sensors, implantable drug delivery systems and bio-electronic devices for the human body defines a new era of medicine to track, support and operate body functions. Here, glucose fuel cells have seen a renaissance in recent years as an implantable power source harvesting energy from readily available fuels in the human body. Compared to existing implantable batteries, glucose fuel cells do not require frequent replacement surgery, due to the abundance and perpetual availability of glucose in the human body. However, state-of-the-art glucose fuel cells are primarily based on polymer electrolytes being relatively bulky, suffer from long-term stability issues and exhibit low power densities. Here, we innovate a miniaturized glucose fuel cell fully composed of solid state materials and based on thin film processing. This all-solid-state glucose fuel cell can be scaled down to the sub-micrometer range for unprecedented miniaturization and is built on a Si-chip suitable for integrated powering of bio-electronic implants. Free-standing fuel cell membranes based on a proton conducting oxide on Si-chips were assembled using a microfabrication route with standard semiconductor processing techniques. Oxide thin films were prepared via pulsed laser deposition. Performance characterizations were carried out via electrochemical impedance spectroscopy and galvanostatic polarization curve measurements. In this work we will show the results of screening more than 100 glucose fuel cells for their performance, and that we can obtain reliable statistics on the open circuit voltage and the power density of all-solid-state glucose fuel cells. We will demonstrate that the first all-solid-state glucose fuel cell, with a roughly 100-fold lowered device thickness compared to polymer-based glucose fuel cells, achieves power densities sufficient to power the next generation of miniaturized implantable bio-medical devices.



Benjamin Cary
bencary@mit.edu
Seeking summer internship.
MEng supervised by Jeffrey Lang.
Available from June 2021.

Research Interests:

Actuators, batteries, biological devices and systems, bioMEMS, electronic devices, electronics, energy, energy harvesting devices and systems, field-emitter devices, lasers, MEMS and NEMS, nanomanufacturing, nanomaterials, nanotechnology.

Implantable Microphones for Fully Implantable Hearing Prosthetics

B. Cary, J. Zhang, E. Olson, H. Nakajima, J. Lang

Sponsorship: NIH

5.05

Assistive hearing devices have enabled the restoration of one of the most important senses for going about daily life. These technologies have changed the lives of millions, but there are also hindrances which arise. Today's devices are bulky, can only be worn during the day, and do not function well in noisy environments. These issues can be addressed by entirely implantable devices and the microphone is the limiting factor. Being entirely encapsulated in the ear, the implants can take advantage of the natural acoustic filtering of the ear, are not a detriment to a person's ability to be physically active and can be worn at night.

Having successfully demonstrated a proof-of-concept, we hope to completely characterize and optimize the performance and fabrication of two types of microphones which will serve the same purpose. One is an intracochlear microphone designed to capture inner ear sound and the other is a drum-like microphone which captures the motion of middle-ear bone structures driven by the eardrum. Transduction of acoustic vibration is achieved utilizing PVDF, a piezoelectric film. As the scale of this film is on the order of millimeters to tens of microns, MEMS fabrication technology is being evaluated for manufacturing the devices. Sensing electronics also play a significant role in the design to minimize noise and undesirable mechanical loading. So far, we have developed numerical and analytical models and will continue to verify their accuracy through experimental processes. These devices will be brought to a stage where they can be safely implanted in humans permanently.

Session 6: Electronic and Quantum Devices 2



Jaeyoung Jung
 jungj@mit.edu
 Seeking summer internship.
 SB supervised by Tomas Palacios.
 Available from June 2021.

Research Interests:
 Electronic devices, electronics, energy, GaN, III-Vs, integrated circuits, photovoltaics.

Simulation and Analysis of GaN CMOS Logic

J. Jung, N. Chowdhury, Q. Xie, T. Palacios

Sponsorship: MIT EECS - Texas Instruments Undergraduate Research and Innovation Scholar

6.01

There is an increasing demand for electronics that can operate in high-temperature conditions, such as spacecraft and sensors for industrial environments. Electronics based on wide-bandgap materials offer a promising solution. Most current demonstrations of GaN logic are based on nMOS technology, which has a high static power consumption. GaN CMOS technology, which has lower static power consumption, is desired.

This work studies the impact of the p-FET device performance on the performance of the CMOS inverter. Industry-standard MVSG (MIT Virtual Source GaN-FET Model) was used to accurately model the behavior of the n-channel and p-channel transistors. The impact of different designs of the p-FET on the performance of the CMOS inverter was evaluated and compared to the performance of the nMOS inverter. This technique will be scaled up for more complex combinational and sequential logic building blocks, with the eventual goal of realizing a GaN CMOS microprocessor.

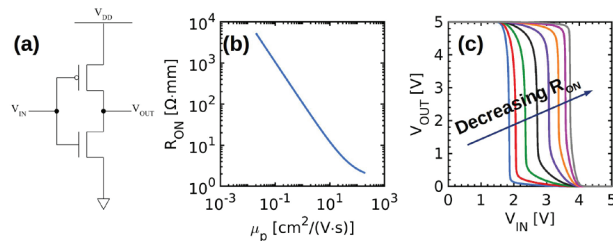

◀ (a) Schematic of CMOS inverter; (b) ON-Resistance of p-channel FET as a function of channel mobility; (c) Impact of ON-Resistance of p-channel FET on voltage transfer characteristics of CMOS inverter.



Murat Onen
 monen@mit.edu
 Seeking summer internship.
 PhD supervised by Karl Berggren.
 Available from June 2023.

Research Interests:
 2D materials, electronic devices, electronics, field-emitter devices, GaN, III-Vs, integrated circuits, nanomanufacturing, nanomaterials, nanotechnology, Si, SiGe and Ge.

Single-Photon Single-Flux Coupled Detectors

M. Onen, M. Turchetti, B. A. Butters, M. R. Bionta, P. D. Keathley, K. K. Berggren

Sponsorship: DARPA DETECT Program

6.02

Superconducting nanowire single-photon detectors (SNSPDs) are prominent tools for these applications because of their >90% detection efficiencies, near GHz count rates, few picosecond timing jitter, broad spectral sensitivity from ultra-violet to infrared wavelengths, and sub-Hz dark count. In this work, we present a novel device that is a combination of an SNSPD and a superconducting multi-level memory. We show that these devices can be used to count the number of detections through single-photon to single-flux conversion. Electrical characterization of the memory properties demonstrates single-flux quantum (SFQ) separated states while optical measurements are shown to differentiate single-photon detection from other possible phenomena, such as multi-photon detection and thermal activation. We suggest this new device may prove analogous to a charge-coupled detector (CCD), as the successive photon detection events lead to linear accumulation of flux (instead of charge for CCDs), which can provide the number of single-photon detection events (analogous to intensity). The further development could devise schemes for readout of large-scale arrays of such devices for use in imaging and spectroscopy.

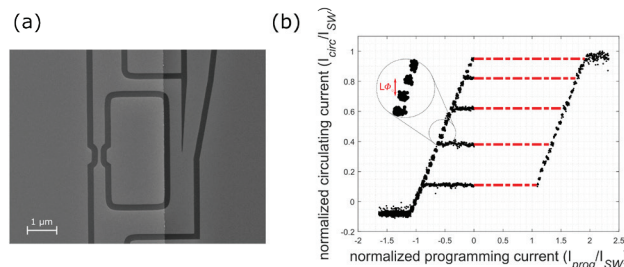

◀ (a) Scanning electron microgram of the detector. (b) Change in flux state of memory as a response to 3 successive detection events demonstrating photon counting operation. The state separation corresponds to a single fluxon difference and are programmed by single photon events.

Quantitative Study on Current-Induced Effects in an Antiferromagnet Insulator/Pt Bilayer Film

P. Zhang, J. Finley, T. Safi, and L. Liu

Sponsorship: NSF, NIST

6.03

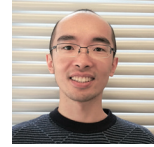

Pengxiang Zhang
 pxzhang@mit.edu
 Seeking summer internship.
 PhD supervised by Luqiao Liu
 Available from June 2023.

Research Interests:
 Electronic devices, nanomaterials,
 nanotechnology, spintronics.

Electrical control and detection of magnetic ordering inside antiferromagnets has attracted considerable interests, for making next generation MRAM with advantages in speed and density. However, a full understanding of the recent prototypical spin-orbit torque antiferromagnetic memory devices requires more quantitative and systematic study.

Here we studied the current-induced switching in a canted antiferromagnetic insulator α -Fe₂O₃, similar to previous demonstrations of antiferromagnetic memories, and also quantified the moment rotation. We raised the concern that the signal in these memory devices can be complicated by two neglected sources that are unrelated to spin-orbit torques, while the confirmed contributions from spin-orbit torques are much smaller than expected. Besides calling for more inspection of previous antiferromagnetic memories, this work also provides a pathway towards the future clean realization of a spin-orbit torque antiferromagnetic insulator memory device.

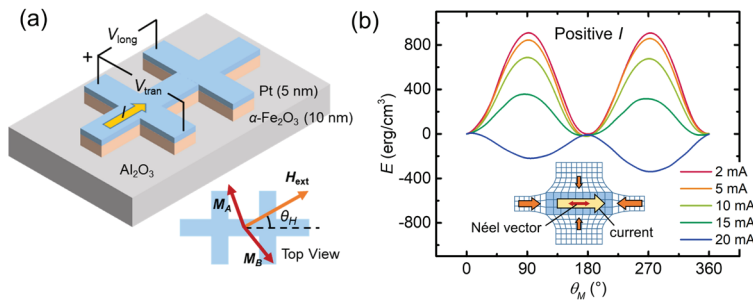

▲ (a) Schematic of the bilayer film, Hall bar geometry and spin Hall magnetoresistance measurement. (b) Angle-dependent magnetic energy as a function of current, showing a Joule-heating-induced magnetoelastic effect and a field-like spin-orbit torque.

Investigation of Dynamic Operation of Negative Capacitance with InGaAs MOSFET in the Multi-GHz Regime

T. Kim, J. A. del Alamo

Sponsorship: Samsung Electronics, Semiconductor Research Corporation

6.04



Taekyong Kim
 ty190kim@mit.edu
 Seeking regular employment.
 PhD supervised by Jesus del Alamo.
 Available from August 2022.

Research Interests:
 2D materials, displays,
 electronic devices, electronics,
 III-Vs, integrated circuits,
 nanomanufacturing,
 nanomaterials, nanotechnology, Si,
 thermal structures, devices and
 systems.

Negative capacitance (NC) by integrating a ferroelectric (FE) layer in the gate stack of a MOSFET has attracted substantial interest. This is due to its potential for achieving amplification of the gate field and a steep subthreshold swing which is desirable for logic applications. For these reasons, various works have analyzed the NC mechanism so far. However, the dynamic response remains obscure and contentious.

The objective of our project is to investigate the frequency response of the NC effect over a broad frequency range. For this study, we have adopted the self-aligned InGaAs MOSFET platform which has demonstrated the highest bandwidth of any FET ever reported. As a FE layer, Hf_{0.5}Zr_{0.5}O₂ (HZO) is chosen, because it is scalable and compatible with CMOS technology.

In this work, we have developed a low-temperature gate stack composed of HZO and Al₂O₃ for InGaAs FE-MOSFETs. MFIM capacitor results will be presented. If available, transistor characteristics will also be reported.

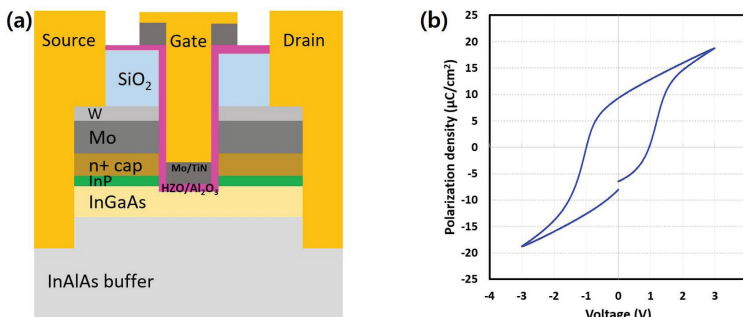

▲ (a) Schematic diagram of InGaAs MOSFET with FE gate stack. (b) Polarization-voltage loop of low-temperature (400°C) TiN / HZO / TiN capacitor at 1 kHz.

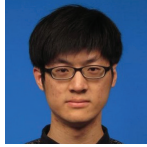

Qihang Zhang
 qhzhang@mit.edu
 Seeking regular employment.
 PhD supervised by Long Ju.
 Available from June 2021.

Research Interests:
 2D materials, optoelectronics,
 sensors.

Study of Magneto-Excitons in a Tunable Bandgap Semiconductor

6.05

Q. Zhang, T. Han, M. Yeung, L. Ju

Sponsorship: NSF, MRL, MIT

Multilayer graphene in the rhombohedral stacking order (AB, ABC, ABCA...) is a unique semiconductor where the bandgap can be continuously controlled by an external electric field. It provides an exciting platform to study conventional exciton physics in the context of valley pseudospin and quantum geometry in an in situ tunable semiconductor bandgap. In previous experiments, we observed tunable exciton states in AB-stacked bilayer graphene with unusual optical selection rules, strong optical resonances and extremely narrow line width. In this poster, I will describe our new observation of inter Landau level transitions in bilayer graphene in a magnetic field. We found unconventional optical selection rules of such transitions, and established the continuous evolution from Coulomb-interaction-dominated to Landau-quantization-dominated optical response. I will also talk about our efforts on using Raman spectroscopy to study the exciton evolution with tunable carrier density, and the search of trion states.

Various experimental techniques such as magneto-transport, scanning tunneling spectroscopy and electronic compressibility measurements have been used to study MLG & BLG, leading to observations of the fractional quantum Hall effect and Hofstadter's butterfly. Our findings provide new insights into the interplay between magnetic field, band structure and many-body interactions in tunable semiconductor systems, and the experimental technique paves the way to studying symmetry-broken states and low energy magneto-optical properties of novel nano and quantum materials.



John Niroula
 jniroula@mit.edu
 Seeking summer internship.
 PhD supervised by Tomas Palacios.
 Available from June 2025.

Research Interests:
 Electronic devices, electronics,
 energy, energy harvesting devices
 & systems, GaN, III-Vs, integrated
 circuits, nanomanufacturing,
 nanomaterials, nanotechnology,
 optoelectronics, quantum devices,
 thermal structures, devices and
 systems.

TCAD Simulation of Vertical Diamond Fin Devices

6.06

J. Niroula, A. Zubair, Q. Xie, N. Chowdhury, J. Perozek, T. Palacios

Sponsorship: DARPA

The introduction of wide-bandgap semiconductors such as Gallium Nitride (GaN) and Silicon Carbide (SiC) have revolutionized the semiconductor electronics industry, especially in the areas of power switching and high frequency RF power amplifiers. While these materials have provided orders of magnitude improvements relative to state-of-the-art silicon devices, today we are beginning to see the limitations of these wide-bandgap materials.

Diamond is an ultra-wide-bandgap semiconductor with extraordinary properties that has the potential for order of magnitude improvements over traditional wide-bandgap semiconductor like GaN and SiC. Its material properties make it the dream material for device engineers. It has high electron and hole mobilities ($>2000 \text{ cm}^2\text{V}^{-1}\text{s}^{-1}$), a large critical field ($>10 \text{ MV/cm}$), and the largest thermal conductivity ($>2000 \text{ Wm}^{-1}\text{K}^{-1}$) of any semiconductor. However, actual diamond device performance has fallen short of its promised material properties, in part due to poor surface trapping and current collapse. In this work, we demonstrate simulations exploring the design space of a novel vertical diamond device structure and compare it to traditional lateral diamond devices to see if a vertical diamond device can mitigate issues prevalent in lateral devices as vertical devices can potentially minimize surface trapping effects, provide better thermal management, and give higher power per areal footprint. These simulations will help to understand the physics of diamond and to guide the fabrication of high performing diamond devices.

CMOS Integration of Control Logic for Solid State Spins

I. Harris, M. Ibrahim, C. Foy, D. Englund

6.07

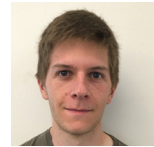

Isaac Harris
ibwharri@mit.edu
Seeking summer internship.
PhD supervised by Dirk Englund.
Available from June 2023.

Research Interests:
MEMS and NEMS,
nanomanufacturing,
nanotechnology, photonics,
quantum devices.

Quantum networks are expected to play an important role in the future of information technology as carriers of secure classical information and as links between networked quantum computers. Color centers in diamond such as the NV- color center are promising candidates for spin-photon interfaces, which act as transducers between stationary quantum memories and carriers of quantum information. To date, demonstrations of the control of color centers have used discrete components to generate the necessary control signals. However, the creation of realistic quantum networking devices will require the integration of hundreds to thousands of color centers into a single device, which makes current control methods impractical. We demonstrate a proof of concept quantum information chip produced using a standard CMOS process for the control of color centers. The chip includes an integrated voltage-controlled oscillator and microwave switches to provide independent control of two color centers. We demonstrate quantum control over NV- color centers in diamond nanostructures integrated on the chip using a pick-and-place process. We further quantify the effects of background fluorescence from the chip on the quality of the signal from the color centers and discuss implications for the integration of large numbers of color centers in a realistic quantum device. This work shows a clear path to the creation of near-term quantum networking devices built with color centers.

Degradation under Forward Bias Stress of Normally-Off GaN High Electron Mobility Transistors

E. S. Lee, J. A. del Alamo

Sponsorship: Texas Instruments

6.08



Ethan S. Lee
ethanlee@mit.edu
Seeking summer internship.
SM supervised by Jesus del Alamo.
Available from May 2022.

Research Interests:
Electronic devices, GaN,
nanotechnology.

Energy efficient electronics have been gaining large attention as a necessary path to meet the growing demand for energy and sustainability. GaN field-effect transistors (FET) show great promise as high-voltage power transistors due to their ability to withstand a large voltage and carry large current. For best circuit reliability and performance, a normally-off transistor is highly desirable. An attractive design is the p-doped GaN gate GaN High Electron Mobility Transistor (p-GaN HEMT).

Our research aims to better understand the reliability issues impeding widespread adoption of p-GaN power HEMTs. One key issue is device degradation under electrical stress where key device performance figures such as the threshold voltage and the gate leakage current change with electrical stress.

Here, we show that device degradation under forward bias electrical stress, i.e. when the transistor is turned on, it undergoes three distinct regimes. We find that these three regimes are thermally activated and are time dependent. Finally, we show that the physics behind the three regimes are different than that of catastrophic forward gate breakdown of the transistor. Our research demonstrates the complex reliability issues present on p-GaN HEMTs that must be well understood before the commercial success of this technology.



Kevin Joseph May
 kmay@mit.edu
 Seeking regular employment.
 Postdoctoral associate supervised
 by Bilge Yildiz.
 Available from June 2021.

Research Interests:

Electronic devices, electronics,
 energy, energy harvesting devices
 and systems, nanomaterials,
 nanotechnology, photovoltaics.

Control of Conductive Filaments in Resistive Switching Oxides

6.09

K. J. May, Y. R. Zhou, T. Ando, V. Narayanan, H. L. Tuller, B. Yildiz

Sponsorship: IBM

There has been a growing interest in using specialized neuromorphic hardware for artificial neural network applications such as image and speech processing. These neuromorphic devices show promise for meeting the significant computational demands of such applications with higher speed and lower power consumption than software-based implementations. One approach to achieving this goal is through oxide thin film resistive switching devices arranged in a crossbar array configuration. Resistive switching can mimic several aspects of neural networks, such as short- and long-term plasticity, via the dynamics of switching between multiple analog conductance states--dominated by the creation, annihilation, and movement of defects within the film (such as oxygen vacancies). These processes can be stochastic in nature and contribute significantly to device variability, both within and between individual devices.

This study focuses on reducing the variability of the set/reset voltages and enhancing control of the conductance state with voltage pulsing using model systems of HfO₂ grown on Nb:SrTiO₃ substrates through the control of film growth and processing parameters. We show that depending on the growth temperature, substrate orientation, and substrate surface treatment, devices can exhibit forming-free switching or forming voltages ranging from 4 to 7 V. Forming-free devices show lower variability in the high and low conductance states but have a lower on/off conductance ratio. We rationalize these results using film microstructure information obtained from 2D X-ray diffraction and cross-sectional transmission electron microscopy. This work provides a significant step towards controlling the mechanisms behind device variability and achieving devices that meet the strict requirements of neuromorphic computing.



Tim Menke
 timmenke@mit.edu
 Seeking summer internship.
 Visiting affiliate supervised by Will
 Oliver.

Research Interests:

2D materials, electronics,
 nanotechnology, quantum devices.

Quantum Landscape Engineering of Superconducting Circuit Ground States for Higher-Order Coupler Design

6.10

T. Menke, C. F. Hirjibehedin, S. J. Weber, J.n Braumüller, A. Vepsäläinen, R. Winik, G. O. Samach, D. K. Kim, A. Melville, B. M. Niedzielski, D. Rosenberg, M. E. Schwartz, J. L. Yoder, A. Aspuru-Guzik, S. Gustavsson, A. J. Kerman, W. D. Oliver

Sponsorship: Office of the Director of National Intelligence, Intelligence Advanced Research Projects Activity, Assistant Secretary of Defense for Research & Engineering under Air Force

Superconducting circuits provide a versatile engineering platform for the study of quantum systems and their use as a computational resource. Their application ranges from studying fundamental principles such as the physics of quantum entanglement to the demonstration of large-scale control of quantum bits simulating spin models in solid state physics. Many-body interactions of multiple spins simultaneously are one aspect of spin models that has not been demonstrated to date.

In this work, we exploit that the response of the quantum ground state energy of a superconducting circuit to external magnetic flux can be shaped by design to engineer artificial spin couplers. We propose a methodology for adding higher-order polynomial terms into the ground state energy versus flux by strongly coupling a series of rf SQUIDS. The fundamental instance of two rf SQUIDS generating a ground state with 4th-order terms is implemented experimentally. Probing this circuit with a sensor flux qubit, the qubit's transition frequency maps the derivative of the quartic ground state in accordance with simulation. Modest levels of qubit coherence are maintained despite the relatively strong inductive coupling. These results demonstrate the viability of this design for use as a 4-local coupler and show promise for extending it to higher polynomial order.

Surface Spin Induced 1/f Flux Noise Dependent on SQUID Geometry

6.11

J. Braumueller, L. Ding, A. Vepsalainen, Y. Sung, M. Kjaergaard, T. Menke, R. Winik, D. K. Kim, B. M. Niedzielski, A. Melville, J. L. Yoder, C. F. Hirjibehedin, T. P. Orlando, S. Gustavsson, W. D. Oliver

Sponsorship: Office of the Director of National Intelligence, Intelligence Advanced Research Projects Activity, Department of Defense via MIT Lincoln Laboratory under Air Force

Superconducting qubits are leading candidates to implement quantum hardware capable of performing certain computational tasks more efficiently than its classical counterpart. A prerequisite for scalable quantum computation is a sufficiently low noise level in the participating qubits. The dominant source of decoherence in frequency tunable superconducting qubits is 1/f flux noise, presumably originating from local magnetic spin impurities located at the surface of their SQUID loops. Here, we measure the flux noise amplitudes of about 50 capacitively shunted flux qubits and study their dependence on geometric parameters of their SQUID loops. Our data show good agreement with a previously presented microscopic model for independent spin impurities which has so far eluded experimental verification. We discuss limitations of the proposed model for superconducting films of finite thickness and provide numerical simulations of the current distribution in our SQUIDS, which can refine the considered model. Our results confirm that flux noise increases with the perimeter and decreases with the wire width of the SQUID loop and may therefore serve as a guide on how to improve the flux noise susceptibility of superconducting circuits in general.

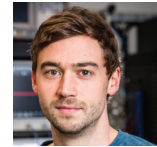

Jochen Braumueller
jbraum@mit.edu
Seeking regular employment.
SM supervised by William Oliver.
Available from July 2021.

Research Interests:

Nanomaterials, nanotechnology, quantum devices, superconductivity. .

Novel Synaptic MOSFET by Gate Stack Engineering

6.12

A. Zubair, K. Limanta, J. Zhu, T. Palacios

Sponsorship: ARPA-E

The field of artificial intelligence and deep learning has made great strides by using state-of-the-art digital processors and accelerators with learning and inference algorithms based on artificial neural networks (ANN). In spite of this exciting progress, training of large DNNs is still a very computationally intensive task, even when using some of the most advanced parallel computing systems available. In parallel to the development of specialized CMOS-based hardware, novel non-volatile memory (NVM) devices based on phase change memory, resistive random memory or floating gate memory devices have been explored to speed up the training process.

Although significant progress has been made in two-terminal NVM for synaptic devices, these devices still suffer from yield, reproducibility, the lack of an optimized selection component and non-symmetric memory setting, which makes the neuron potentiation very different from the de-potentiation. In this project, we use a conventional MOSFET as the synaptic device. An engineered gate stack stores the synaptic weights in as changes in the threshold voltage of the transistor. The simplicity and well understood behavior of the proposed field-effect transistor makes it attractive for scaling and integration with existing technology. These synaptic MOSFETs when optimized can provide improved synaptic weights by allowing faster, more reliable and more symmetric updating than NVMs and having very long retention times compared to CMOS.



Ahmad Zubair
azubair@mit.edu
Seeking regular employment.
PhD supervised by Tomás Palacios.

Research Interests:

2D materials, electronic devices, electronics, energy harvesting devices & systems, GaN, nanomaterials, nanotechnology, optoelectronics, quantum devices.



Miguel Sanchez-Lozano
 mslozano@mit.edu
 Seeking summer internship.
 Visiting affiliate supervised by
 Tomas Palacios.

Research Interests:
 2D materials, BioMEMS, GaN,
 nanotechnology, optoelectronics,
 sensors.

Novel Gate Technology for High Frequency Transistors

6.13

M. Sanchez-Lozano, T. Palacios

Sponsorship: IBM, UPM

The long-term goal of this project is to demonstrate the highest frequency High Electron Mobility Transistors (HEMTs) ever fabricated in Gallium Nitride. For this, in this work we have developed a sub-30 nm T-shaped gate technology in a double-exposure process and in wet etching technology of this kind of Nitride. We can achieve this resolution using electron beam lithography of high voltage (125 kV) on a highly sensitivity photoresist, cold development and optimizing the process. the cross-section area was maximized (due to the increasing of the area in the upper part) to minimize the resistance of the material, while the gate stack is hold by a thin layer of oxide and creating a wet-etching shape underneath to minimize the parasitic capacitance.

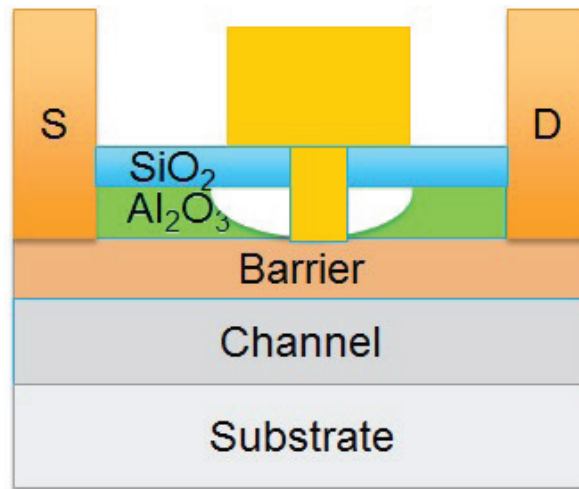

▲ Schematic design of the final model of a T-gate cross-section.



Daniel Rodan-Legrain
 drodan@mit.eu
 Seeking regular employment.
 PhD supervised by Pablo Jarillo-
 Herrero
 Available from September 2022.

Research Interests:
 2D materials, electronic devices,
 nanotechnology, quantum devices.

Magic-Angle Graphene Superlattices: a New Platform for Strongly Correlated Physics

6.14

D. Rodan-Legrain, Y. Cao, O. Rubies-Bigorda, J. M. Park, D. Chowdhury, V. Fatemi, S. Fang, K. Watanabe, T. Taniguchi, E. Kaxiras, T. Senthil, P. Jarillo-Herrero

Sponsorship: NSF Center for Integrated Quantum Materials, Gordon and Betty Moore Foundation, Obra Social "La Caixa"

The understanding of strongly-correlated quantum matter has challenged physicists for decades. Such difficulties have stimulated new research paradigms, such as ultra-cold atom lattices for simulating quantum materials. We here present a new platform to investigate strongly correlated physics, based on graphene moiré superlattices. In particular, when two graphene sheets are twisted by an angle close to the theoretically predicted 'magic angle', the resulting flat band structure near the Dirac point gives rise to a strongly-correlated electronic system. These flat bands exhibit half-filling insulating phases at zero magnetic field, which we show to be a correlated insulator arising from electrons localized in the moiré superlattice. Moreover, upon doping, we find electrically tunable superconductivity in this system, with many characteristics similar to high-temperature cuprates superconductivity. These unique properties of magic-angle twisted bilayer graphene open up a new playground for exotic many-body quantum phases in a 2D platform made of pure carbon and without a magnetic field. We also present data demonstrating nematicity in the superconducting state, strange metal behavior at correlated fillings with near Planckian dissipation as well as correlated states in other types of graphene superlattices. This novel platform may pave the way towards more exotic correlated systems, tunable superconducting qubits, and fully-integrated 2-dimensional electronics for the future nanodevice technology.

Lined writing area consisting of multiple horizontal blue lines.

Session 7: Photonics and Optoelectronics

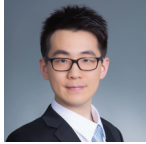

Tianyi Han
tyhan@mit.edu
Seeking regular employment.
Postdoctoral associate supervised
by Long Ju.
Available from February 2021.

Research Interests:

2-D materials, electronic devices,
nanomaterials, nanotechnology,
quantum devices.

Engineering Inter-Landau Level Transitions in Graphene for Tunable THz Optical Devices

T. Han, Q. Zhang, L. Ju

Sponsorship: NSF Center of Integrated Quantum Materials, MIT Physics Department

Terahertz (THz) electromagnetic waves host great promises for both fundamental research and technological applications. However, compared to the well-developed technologies in the electronic and photonic frequency ranges, our current methods to generate, manipulate and detect THz waves are far-less developed. In this work, I will present our efforts of improving THz techniques by engineering the optical response of monolayer graphene in the THz range. We fabricated high-quality graphene devices with Corbino geometry (as shown in figure). With FTIR photocurrent spectroscopy, we obtained their optical absorption spectrum in a magnetic field. We were able to resolve sharp inter-Landau level absorption peaks in mid-infrared to THz regime. Furthermore, we can tune these peaks continuously with magnetic fields and gate electric fields to cover up to 10 THz with up to 1 Tesla. I will also discuss schemes to enhance the detectivity and a novel spectroscopy technique based on our observations.

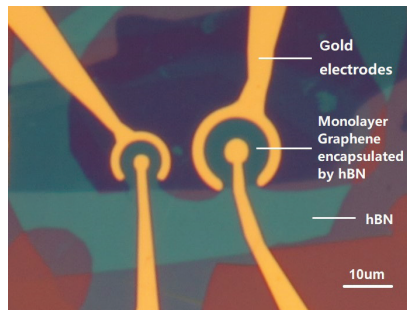

◀ Optical image of our hexagonal Boron Nitride (hBN) encapsulated graphene device with the Corbino geometry.



Jordan Goldstein
jordango@mit.edu
Seeking summer internship.
PhD supervised by Dirk Englund.
Available from June 2020.

Research Interests:

2-D materials, communications,
nanomaterials, nanotechnology,
optoelectronics, photonics,
sensors.

Graphene-Loaded Slot Antennas for Multispectral Thermal Imaging

J. A. Goldstein, D. R. Englund

Sponsorship: ARO via ISN-4 research grant

Color cameras are ubiquitous in everyday life. However, most color imagers rely on color filter arrays (CFAs), resulting in most incoming light being filtered out instead of detected. More generally, for a filter-based imaging array with N different colors, only $1/N$ of the incoming light is actually used. While lossless spectral imagers are available, they rely on bulky optics such as diffraction gratings or interferometers to achieve spectral resolution, which is often undesirable. In the thermal IR wavelength range, the problem of filter loss is exacerbated by reduced sensor detectivity compared to visible light sensors. We propose an efficient and compact thermal IR spectral imager based on a metasurface consisting of sub-wavelength-spaced, differently-tuned antennas with photosensitive loads. The different antenna resonances combine to yield broadband optical energy transfer to the loads exceeding the $1/N$ efficiency limit of CFAs. In particular, we investigate slot antennas due to their unidirectionality and high efficiency compared to typical dipole antennas. We use graphene as our photosensitive load because its 2D nature makes it easily adaptable to this imager architecture. To aid in the design of these slot antenna metasurfaces, we establish a circuit model for the optical properties of the antennas and demonstrate consistency between this model and full-wave electromagnetic simulations. We also show simulation results demonstrating broadband ~40% free space to graphene coupling efficiency for a six-spectral-band metasurface. Finally, we demonstrate a fabrication process which yields slot antennas with smooth surfaces suitable for graphene transfer on top. This research represents the first steps towards compact, monolithic, and potentially CMOS-integratable mid-IR spectral imagers whose low bulk and low energy consumption suit them for deployment on small drones for remote sensing and free-space communication purposes.

7.01

7.02

VCSEL-Based QCSE Modulator Arrays for Optical Neural Networks

L. Ateshian, R. Hamerly, L. Bernstein, A. Sludds, D. Englund

Sponsorship: NSF Graduate Research Fellowship

7.03



Lamia Ateshian
ateshian@mit.edu

Seeking summer internship.

PhD supervised by Dirk Englund.

Available from June 2025.

Research Interests:

Lasers, optoelectronics, photonics, quantum devices.

Recently, deep neural networks (DNNs) have become instrumental in fields such as image processing, speech recognition, robotics, and several others. However, training and running inference on DNNs is computationally intensive, requiring significant energy resources in data centers. This has motivated companies and researchers to develop special purpose hardware for running DNNs such as TPUs, GPUs, and ASICs. In recent work, we proposed a method to accelerate neural network computations, leveraging massive optical fanout and ultrafast matrix-matrix multiplication. In this scheme, data is modulated onto an optical pulse train and fanned out to photodetectors to perform the calculations.

We are currently working on a coherent modulator array to encode the data onto the optical carrier. Previous implementations of modulators occupied large footprints, limiting their scalability to dense arrays. Here we investigate arrays of vertical-cavity surface-emitting lasers (VCSELs) operating as electro-absorption modulators, as they offer dense integration, high-speed modulation, and low energy consumption. They also operate at suitable wavelengths for detection with CMOS detector arrays. The modulation relies on the quantum-confined Stark effect (QCSE), in which reverse-biasing the multiple quantum well structure in the VCSELs shifts the photon absorption spectrum, thereby amplitude-modulating incident light. Injection locking an array of VCSELs could enable coherent transmission. We present here the operating principle of the VCSEL-based QCSE modulators, preliminary characterization data, and an outline of next steps for incorporation into our optical neural network. The proposed optical DNN accelerator would be scalable to large matrices with millions of entries and able to operate at high speed and very low energies, potentially revolutionizing deep learning hardware.

Hafnia-Filled Photonic Crystal Emitters for Micro-Scale Thermophotovoltaic Energy Generation

R. Sakakibara, V. Stelmakh, W.R. Chan, R. Geil, M. Ghebrebrhan, J.D. Joannopoulos, M. Soljačić, I. Čelanović

Sponsorship: Army Research Office, U.S. Department of Energy

7.04

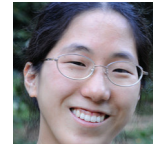

Reyu Sakakibara
reyu@mit.edu

Seeking summer internship.

PhD supervised by Ivan Čelanović and John Joannopoulos.

Available from January 2021.

Research Interests:

2-D materials, electronic devices, information processing, nanomanufacturing, nanotechnology, quantum devices, spintronics.

Thermophotovoltaic (TPV) systems are promising as small scale, portable generators for power sensors, small robotic platforms, and portable computational and communication equipment. In TPV systems, an emitter at high temperature emits radiation that is then converted to electricity by a low bandgap photovoltaic cell. One approach to increase both TPV power and efficiency is to use two-dimensional, hafnia-filled tantalum photonic crystals (PhCs). These emitters enable efficient spectral tailoring of thermal radiation for a wide range of incidence angles. However, fabricating these PhCs is difficult. In particular, filling the PhCs' deep cavities using atomic layer deposition leads to an uneven and thick top surface that adversely impact the PhC emittance. We explore methods to planarize and etch back the top surface, which can enable high TPV performance and pave the way toward portable micro-generators for off the grid applications.

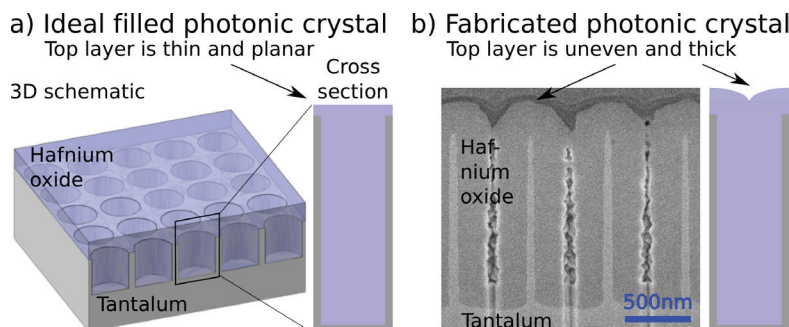

▲ (a) Schematic of an ideal filled photonic crystal (PhC) and its cross section, which have a flat and thin top surface. (b) Focused ion beam image of the fabricated filled PhC cross section shows a thick, uneven layer of hafnia above the cavity.



Jérôme Michon
 jmichon@mit.edu
 Seeking regular employment.
 Postdoctoral associate supervised
 by Juejun Hu.
 Available from July 2020.

Research Interests:
 Electronic devices, electronics,
 III-Vs, integrated circuits,
 lasers, light-emitting
 diodes, nanomanufacturing,
 nanomaterials, nanotechnology,
 optoelectronics, photonics,
 photovoltaics, quantum devices,
 sensors, spintronics.

A 3-D integrated Photonics Platform with Deterministic Geometry Control

7.05

J. Michon, S. Geiger, L. Li, C. Gonçalves, H. Lin, K. Richardson, X. Jia, and J. Hu
 Sponsorship: NSF

3-D photonics promises to expand the reach of photonics by enabling both the extension of traditional applications to non-planar geometries and adding novel functionalities that cannot be attained with planar devices. However, current fabrication methods limit the range of available materials options (e.g. to low index contrast polymers for 3-D printing) or device geometries (e.g. to curvilinear geometries that are inherently 2-D in topology). In this work, we report a fully-packaged 3-D integrated photonics platform with devices placed at arbitrary pre-defined locations in 3-D using a fabrication process that capitalizes on the buckling of a 2-D pattern, and present theoretical and experimental validation of the deterministic buckling process. Amenability of the platform for mechanical strain sensing, e.g. in 3-D cell cultures, is further demonstrated to exemplify the unique applications of 3-D integrated photonics.

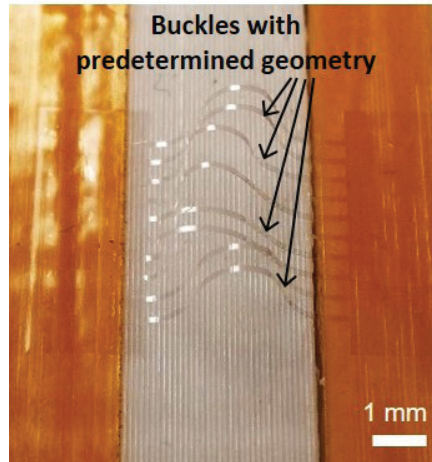

◀ Photograph of an array of 3-D photonic integrated pressure sensors.



Liane Bernstein
 lbern@mit.edu
 Seeking summer internship.
 PhD supervised by Dirk Englund.

Research Interests:
 Lasers, multimedia,
 optoelectronics, photonics,
 artificial intelligence, neural
 networks.

Optical Neural Networks: Experimental Progress

7.06

L. Bernstein, A. Sludds, R. Hamerly, D. Englund
 Sponsorship: Natural Sciences and Engineering Research Council of Canada

Artificial intelligence is becoming ubiquitous in our society; specifically, artificial neural networks (NNs) have enabled breakthroughs in image classification, translation and prediction. The recent adoption of NNs in a wide variety of fields is largely due to algorithms with improved accuracy that leverage more compute power and larger datasets. However, throughput and energy efficiency are currently limiting the further expansion and adoption of NNs. We have proposed optical neural networks (ONNs), which we have theoretically shown to achieve low-energy, high-throughput NN processing. Here, we present our latest results, including a proof-of-concept demonstration of a digital ONN with no drop in classification accuracy on the MNIST dataset. In this scheme, we use optics for passive data fan-out and routing, which may enable higher-throughput NN hardware. This work showcases the promise of ONNs as a new computing paradigm, which is required to unlock the full potential of NNs.

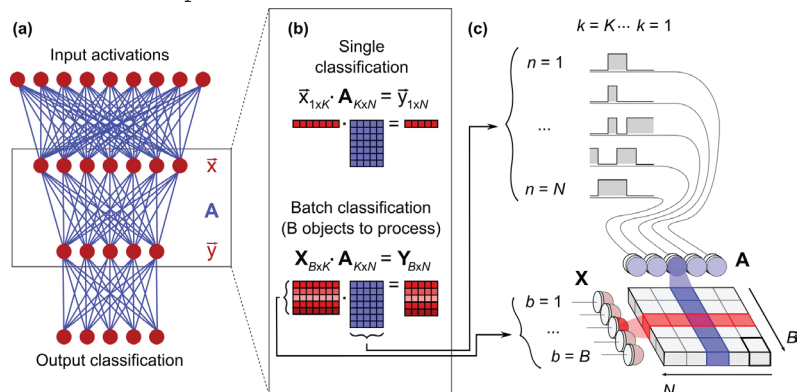

▲ (a) Fully-connected neural network (FC-NN). (b) Matrix formulation of FC-NN. (c) Optical implementation of FC-NN.

Integrated Liquid-Crystal Devices for Visible-Light Modulation

M. Notaros, J. Notaros, M. Raval, M. R. Watts

Sponsorship: DARPA VIPER Program, NSF Graduate Research Fellowship

7.07



Milica Notaros
mnotaros@mit.edu
Seeking summer internship.
SM supervised by Michael Watts.

Research Interests:
Displays, photonics.

Integrated photonics systems at visible wavelengths have many wide-reaching applications, including image projection systems and optogenetics. Generally, these visible-light integrated systems are based on silicon-nitride (SiN) waveguides, since SiN is transparent at visible wavelengths. However, SiN has insignificant thermo- and electro-optic properties, which makes integrated visible-light modulation a challenge. As a solution, liquid crystal (LC), with strong birefringence in the visible spectrum, can be integrated on top of an SiN waveguide to tune the refractive index of the mode in the waveguide and enable modulation. In this work, an integrated LC phase modulator was experimentally demonstrated with a 2π -phase-shift length of $24.4\mu\text{m}$ and an LC variable-tap amplitude modulator was experimentally demonstrated with a coupler length of $10\mu\text{m}$; both devices operate within $\pm 3\text{V}$. These compact modulators enable low-power small-form-factor integrated systems at visible wavelengths.

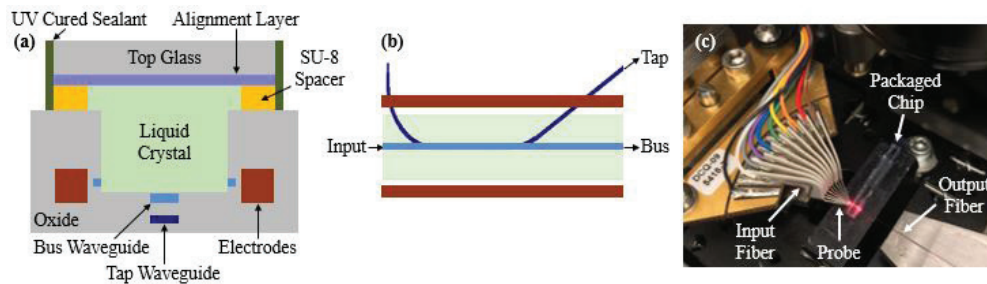

▲ (a) Cross section of the liquid-crystal-based variable-tap amplitude modulator. (b) Top view of the liquid-crystal-based variable-tap amplitude modulator. (c) Photograph of the packaged chip and experimental setup.

Single-Element, Aberration-Free Fisheye Metalens

M. Y. Shalaginov, S. An, C. Rios, F. Yang, P. Su, D. Lyzwa, A. Agarwal, H. Zhang, J. Hu, T. Gu

Sponsorship: DARPA EXTREME Program

7.08



Mikhail Y. Shalaginov
mys@mit.edu
Seeking regular employment.
Postdoctoral Associate supervised
by Juejun Hu.

Research Interests:
Nanomanufacturing, photonics,
quantum devices, sensors.

Wide-angle optical functionality is crucial for advanced imaging and sensing devices. Conventionally, wide-angle operation is attained with complex assembly of multiple optical elements, which substantially increases size, weight and cost. Recent advances in nanophotonics led to metalenses, a new class of ultra-thin planar lenses utilizing subwavelength nanoantennas to gain full control of phase, amplitude, and polarization of light. Here we present a novel metalens capable of performing diffraction-limited focusing and imaging over an unprecedented $> 170^\circ$ angular field of view (FOV). The metalens consists of only a single-layer metasurface monolithically integrated on a one-piece flat substrate. We fabricated the metalens using PbTe Huygens meta-atoms operating at $5.2\mu\text{m}$ wavelength and experimentally demonstrated aberration-free focusing and imaging over the entire FOV. The design concept is generic and can be readily adapted to different meta-atom geometries and wavelength ranges.

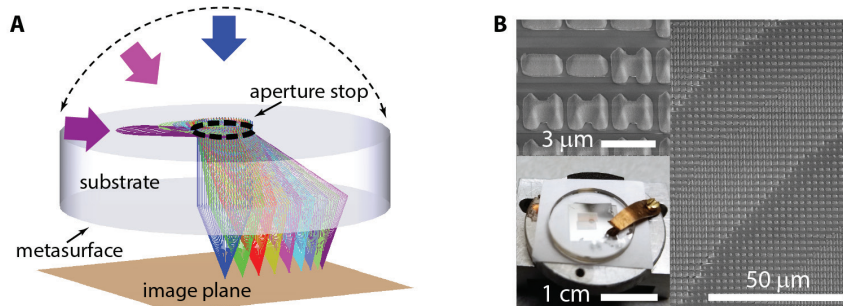

▲ (a) Schematic of 'fisheye' metalens and (b) Images of the fabricated metasurface composed of lead telluride nanostructures on a calcium fluoride substrate.



Ting-An Lin
 tinganl@mit.edu
 Seeking summer internship.
 PhD supervised by Marc Baldo.
 Available from August 2022.

Research Interests:
 Displays, energy harvesting devices & systems, light-emitting diodes, optoelectronics, organic materials.

Strategies Toward High Performance Solid-State Triplet-Triplet Annihilation Based Photon Upconversion

7.09

T.-A. Lin, C. F. Perkinson, M. A. Baldo
 Sponsorship: U.S. Department of Energy

Photon upconversion (UC) based on triplet-triplet annihilation (TTA) has promising applications such as potential to break the conventional efficiency limit of photovoltaics. In practice, a TTA-UC device having high efficiency at low excitation intensity is desirable. However, the reported performance in dry-processed solid-state is limited due to energy back transfer and material aggregation, which may complicate the integration with applications subject to solvent damages. Here, we propose strategies to reduce the losses. Based on a bilayer of an absorbing and an upconverting material, back transfer is reduced by inserting a blocking layer in between while aggregation is mitigated by doping the absorber into a host material. The upconversion efficiency had a 7-fold enhancement with the excitation intensity reduced by 9 times. The result suggests the strategies as effective approach to high performance dry-processed TTA-UC that can be easily integrated with solid-state applications.

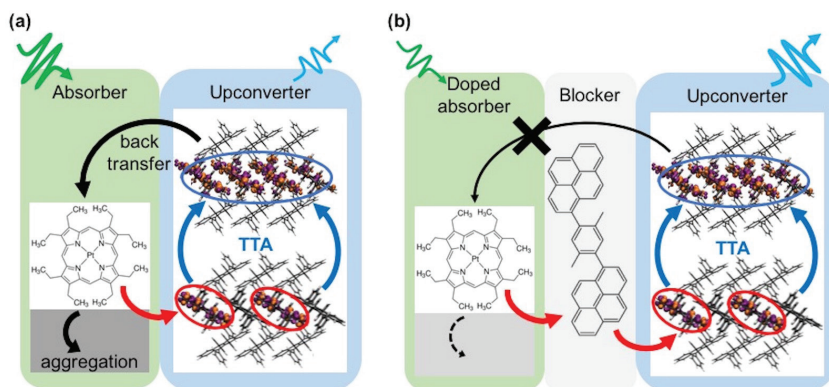

▲ Scheme for a TTA upconversion system of (a) simple bilayer structure and (b) improved device architecture.

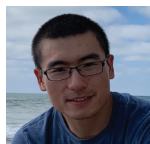

Zhengxing Zhang
 zhxzhang@mit.edu
 Seeking summer internship.
 PhD supervised by Duane Boning.
 Available from June 2022.

Research Interests:
 Integrated circuits, photonics, numerical method.

Adjoint-Based Sensitivity Analysis for Silicon Photonic Variations

7.10

Z. Zhang, S. I. El-Henawy, A. Sadun, R. Miller, L. Daniel, J. K. White, M. B. McIlrath, D. S. Boning
 Sponsorship: AIM Photonics

Due to its ability to support high data rates, silicon photonics is rising as a promising technology platform for various applications. However, it is being hindered by the lack of mature models and methods that capture the impact of manufacturing process variations (PV). Understanding such effects at the component level usually involves numerical simulations to understand light-guiding from Maxwell's equations, which can be very time-consuming, due to the many samples and fine mesh resolution required. In this work, we present a technique that enables fast wavelength-dependent sensitivity analysis for silicon photonic components, where we implement the adjoint method so that only a few simulations are required for the analysis. This method provides good estimation of the impact of various types of PV, thus will enable designers to predict the robustness of their component design against PV with minimal cost, and help achieve high-yield photonic integrated circuits in the future.

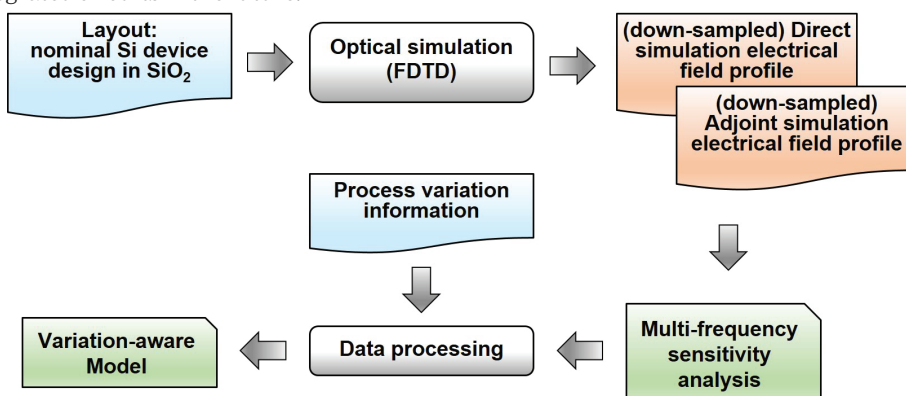

▲ Typical flow of adjoint-based sensitivity analysis for silicon photonic components

Integrated-Photonics-Based Holographic Projector for Augmented Reality

M. Notaros, J. Notaros, M. Raval, M. R. Watts

Sponsorship: DARPA VIPER program, NSF Graduate Research Fellowship

7.11



Jelena Notaros
notaros@mit.edu
Seeking regular employment.
PhD supervised by Michael Watts.

Augmented-reality head-mounted displays that display information directly in the user's field of view have many wide-reaching applications in defense, medicine, engineering, gaming, etc. However, current commercial head-mounted displays are bulky, heavy, and very indiscreet. Moreover, these current displays are not capable of producing holographic images with full depth cues; this lack of depth information results in users experiencing eyestrain and headaches that limit long-term and wide-spread use of these displays. To address these limitations, we have developed a novel integrated-photonics-based display that consists of a single transparent chip that sits directly in front of the user's eye. The display is comprised of 1,024 integrated-optical-phased-array pixels that emit light with the appropriate amplitudes and phases to form a hologram that only the user can see. It presents a highly-discreet and fully-holographic solution for the next generation of augmented-reality displays.

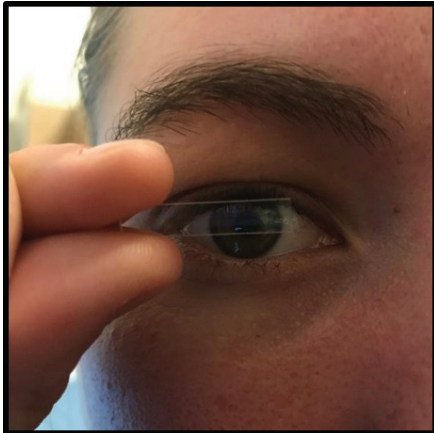

◀ Photograph of the transparent integrated-photonics-based holographic display.

Amorphous Germanium Waveguides for Evanescent Sensing in the Mid - Longwave Infrared

E. Postelnicu, S. Aggarwal, R. Chen, M. Nunez, P. Su, D. Ma, J. Michel, L.C. Kimerling, K. Wada, A. Agarwal

Sponsorship: MIT Lincoln Laboratory ACC

7.12



Eveline Postelnicu
eviolin@mit.edu
Seeking summer internship.
PhD supervised by Lionel Kimerling.
Available from June 2022.

Fabricating CMOS-compatible and economically efficient Mid - Longwave Infrared waveguides that are easily integrated onto a Si platform is of the utmost importance for expanding sensing capabilities. The advantage of amorphous Ge is it can be used to sense organic molecules for both biomedical and environmental sensing and utilizes room temperature processing that is not only economically efficient but can also be flexible with respect to substrate. Thin films of amorphous Ge were obtained using Electron Beam Evaporation (E-beam) and characterized. Ellipsometry performed on the amorphous Ge samples at a wavelength range of 1.5 to 15 microns showed that the index of refraction of E-beam evaporated Ge lies in the 4-4.5 range, very comparable to crystalline Ge. The extinction coefficient for E-beam Ge was used to estimate the material's intrinsic loss, 0.9 dB/cm, which is very promising for low loss waveguides. X-Ray Diffraction confirmed the amorphous nature of the deposited Germanium and Hall Effect measurements show low carrier concentration, 10^{15} cm^{-3} , potentially indicating low free carrier loss in the material as well.

We developed a process for fabrication of low loss amorphous Ge waveguides on FZ-Si to act as a viable solution for sensing in the fingerprint region of the LWIR. Lithography was used to mask the waveguide pattern with dimensions determined by FDTD simulations for single-mode operation. Reactive ion etching was then used to define the waveguide structure and optimized using chlorine, fluorine, and bromine-based etching recipes. Scattering losses due to surface roughness caused by reactive ion etching were characterized using SEM and AFM and minimized to produce low loss waveguides operating in the Mid to Longwave IR. Ultimately, we present a low cost amorphous Ge platform demonstrating low loss sensing in the Mid to LWIR with promising applications for Si integration in the future.

Research Interests:
Integrated circuits, optoelectronics, photonics, sensors, SiGe and Ge.



Ava Waitz
avawaitz@mit.edu

Microfluidic Diffraction Grating Using Fluids of Varied Refractive Indices

7.13

A. Waitz

Sponsorship: MIT.nano, MIT EECS

Microfluidic diffraction gratings can be applied in the areas of micro total analysis systems, environmental sensors, low-cost spectrometers, and actuators. Development of device designs for these applications is needed in order to improve their tunability, sensitivity and accuracy. In this study, gratings were fabricated with two inlet ports and a single switch-back channel. These gratings were then filled with fluids of varied refractive indices to produce different diffraction patterns under a laser. The observed diffraction patterns were compared to theory. Additionally, a method is proposed for producing more complex diffraction patterns by alternating between two fluid types in a periodic fashion. This method is made possible by the dual inlet single channel design.

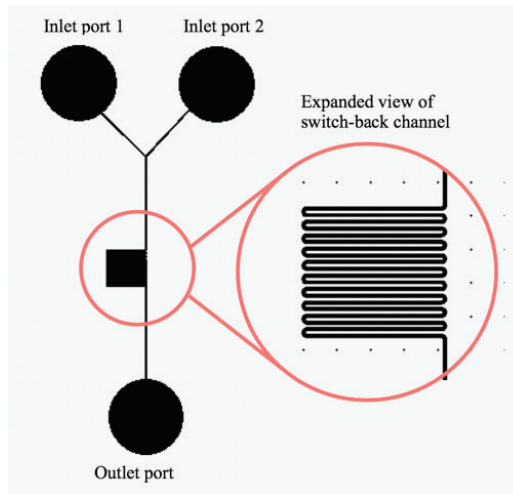

◀ Schematic of microfluidic diffraction grating device. This design includes two inlet ports and a single switchback microchannel.

Session 8: Materials & Manufacturing

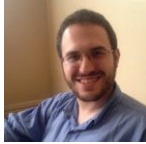

Yosef Kornbluth
ykornblu@mit.edu
Seeking summer internship.
PhD supervised by Luis Velásquez-García.
Available from May 2021.

Research Interests:
2-D materials, electronic devices, MEMS & NEMS, microfluidic devices and systems, nanomanufacturing, nanotechnology.

Electrostatic Improvement of Sputtered Microstructure

Y. Kornbluth, R. M. Matthews, L. Paramswaran, L. Racz, L. F. Velásquez-García
Sponsorship: U.S. Air Force

8.01

Traditional sputtering relies on elevated substrate temperatures and vacuum deposition to ensure that deposited metal retains the dense structure and high electrical conductivity of the sacrificial target. These approaches are incompatible with new, agile manufacturing processes such as micro-sputtering. Micro-sputtering, or sputtering at atmospheric pressure and sub-millimeter scales, allows for the addition of small, conductive features printed directly on nearly any substrate, but the material quality must be suitable.

We describe a method that, by using electric fields to accelerate charged material towards a substrate, enables dense, conductive deposits through atmospheric pressure micro-sputtering without heating the substrate. This method results in conductivity that is within an order of magnitude of that of bulk metal and thin film adhesion better than that achieved in traditional sputtering.

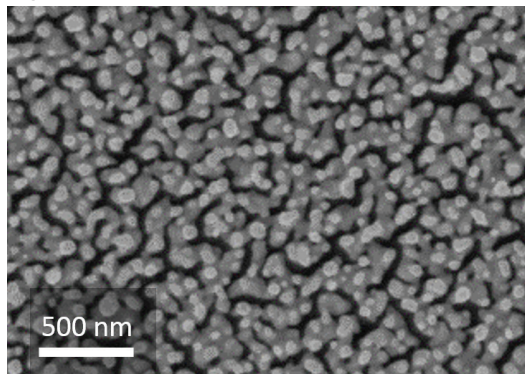

◀ A SEM image of a conductive gold deposit printed by micro-sputtering. This line, printed with an electrically biased substrate, has a resistivity of $15 \mu\Omega\text{-cm}$, 5x that of bulk gold. The nanoparticles that clump together, enhancing the conductivity.



Dulce Viridiana Melo Máximo
virimelo@mit.edu
Visiting affiliate supervised by Luis Velásquez-García.

Surface Modification of Additively Manufactured Components

D. V. Melo-Máximo, L. F. Velásquez-García
Sponsorship: MIT-Tecnológico de Monterrey Nanotechnology Program

8.02

Additive manufacturing is the process of joining materials to make objects through a layer-by-layer deposition. Some of its advantages include manufacturing a piece from a 3D model, the use of various materials, and the low cost. The combination of 3D printing with processes that modify the surface properties can make the use of these components viable in microsystems fabrication. The main objective of this work is to find materials that can withstand chemical reagents and temperatures used in hydrothermal growth of nanowires to increase the wettability. The principal disadvantage of 3D printed resins is the low-temperature work condition, in most of them form cracks after the hydrothermal process. The samples were analyzed with a Confocal Microscope and Scanning Electron Microscope to determine the change in roughness and properties and the presence of surface cracks after the test. This research opens up opportunities for further developments in 3D printed devices.

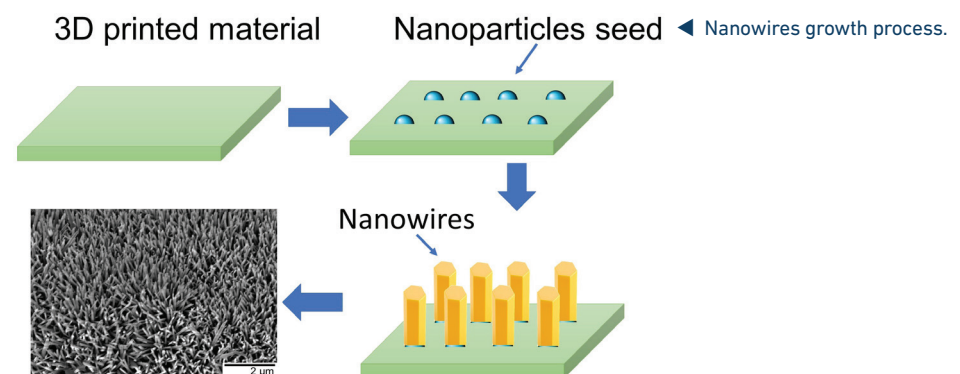

Adopting and Characterizing 3D Cell Culture for In vitro Plant Studies

A. L. Beckwith, J. T. Borenstein, L. F. Velásquez-García

Sponsorship: Draper

8.03



Ashley Beckwith
ashbeck@mit.edu

Seeking regular employment.

PhD supervised by Luis Velásquez-García.

Available from May 2021.

Research Interests:

Biological devices and systems, BioMEMS, medical devices and systems, microfluidic devices and systems.

In vitro plant culture models provide valuable insights into factors governing plant growth and development. Improved understanding of genetic and biochemical pathways in plants has facilitated advancements in a variety of industries: from guiding the development of more robust crops to enabling increased biofuel yields by tuning biomass genetics. Despite the utility of plant culture models, translation of cellular findings to the plant-scale is hindered in current systems. These limitations are, in part, because culture systems fail to recapitulate physical aspects of the natural cellular environment. This work investigates the role of extracellular mechanical and chemical influences on cell development and growth patterns. Early results indicate that tuning of biomechanical and biochemical cues leads to cell growth which deviates from typical culture morphologies and better resembles natural plant physiology. Modifying culture characteristics thus yields more relevant model systems.

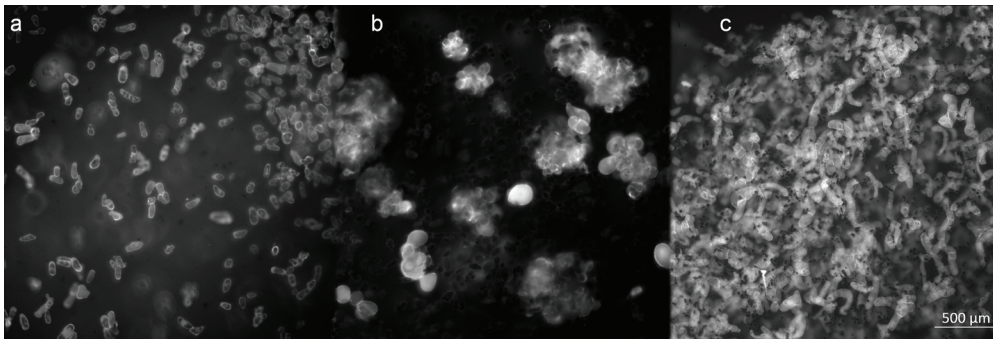

▲ *Zinnia elegans* cells (a) in liquid culture remain morphologically similar to their starting condition, whereas cells in gel culture may be induced to grow in patterns of (b) bulbous, cell aggregates, or (c) uncoordinated, cell elongation.

Rapid Uniformity Tuning in Ion Implantation Systems Using Bayesian Optimization

C. Lang, D. S. Boning

Sponsorship: Applied Materials

8.04

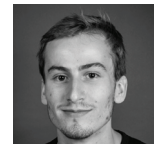

Christopher Lang
langc@mit.edu

Seeking summer internship.

PhD supervised by Duane Boning.

Available from June 2020.

Research Interests:

Information processing, molecular and polymeric materials, nanomanufacturing, machine learning, pattern dependent variations, spin coating, electro chemical plating, process modelling.

As the size of integrated circuits continue to shrink, variations in their fabrication processes become more significant, hindering their electrical performances and yields. One such wafer-scale variation occurs in ion implantation processes, where an ion beam implants charged particles into a substrate. As the beam is scanned across the wafer, its shape and intensity often change, resulting in a non-uniform implantation. This effect can be compensated for by adjusting the speed of the ion beam as it moves across the wafer; however, in order to do so, the dynamics of the ion beam shape must be known.

Our work focuses on using Bayesian optimization, a form of reinforcement learning, to rapidly learn how the beam shape changes, and to optimize the beam speeds in order to reduce non-uniformities. This allows us to optimize an ion implantation process with minimal new data collection, allowing for efficient tuning of the equipment.

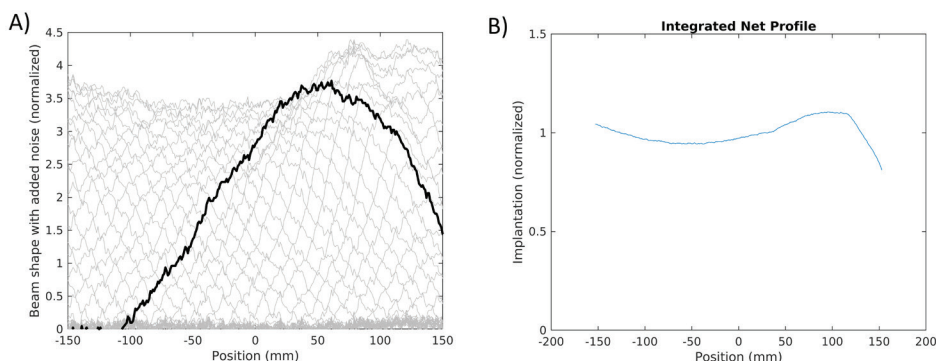

▲ Image showing how the beam shape changes as a function of wafer position (A) and resulting implantation using constant beam speed (B).

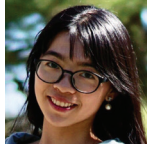

Yuqin Duan
 sophiayd@mit.edu
 Seeking summer internship.
 PhD supervised by Yufeng Chen.
 Available from May 2024.

Research Interests:
 2-D materials, actuators, electronics, energy, energy harvesting devices and systems, MEMS and NEMS, sensors, systems.

High Power Density Dielectric Elastomer Actuators for the Design of Flapping Wing Aerial Robots

8.05

Y. Duan, Y. Chen

Sponsorship: EECS Edwin Webster Fellowship

Insect-scale aerial robots have the potential to navigate in cluttered and complex environments that are difficult for existing drones and quadrotors. Current state-of-the-art micro-aerial-vehicles (MAV) are powered by rigid actuators such as piezoelectric bimorphs and electromagnetic motors, and they are fragile against in-flight collisions. To improve collision robustness, a recent work demonstrated controlled hovering flights and passive in-flight collision recovery in a microrobot powered by soft artificial muscles. However, the power density of electrically actuated polymer (EAP) actuators is approximately half that of the piezoelectric actuators, which severely limits robot payload capability and control authority.

In this work, we present recent development on material selection and fabrication process of dielectric elastomer actuators (DEA). Through using a new elastomer of higher dielectric strength and lower viscoelasticity, we achieve an over 400% improvement in actuator output power density and 200% improvement in efficiency. This result leads to substantial performance improvement of MAVs powered by soft actuators, and further paves the way for future development of power autonomous, soft-actuated aerial robots.

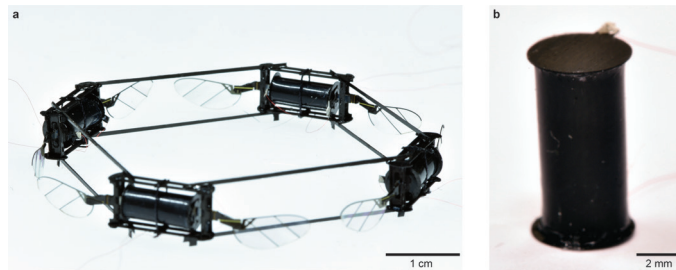

▲ (a) A photograph of a 650 mg flapping-wing aerial microrobot that is powered by four dielectric elastomer actuators. (b) A photograph of a single dielectric elastomer actuator that weighs 105 mg.



David Amirault
 davidja@mit.edu
 Seeking regular employment.
 MEng supervised by Duane Boning.
 Available from June 2020.

Research Interests:
 Information processing, manufacturing systems, machine learning.

Spatial-Temporal Graph Neural Networks for Modeling Automated Material Handling System Traffic

8.06

D. Amirault

The throughput of a modern semiconductor fabrication plant (FAB) depends greatly on the performance of its automated material handling system (AMHS). Improving the traffic routing efficiency of an AMHS increases the utilization of existing hardware and decreases production latency, which is desirable to semiconductor manufacturers. Heuristic-based AMHS traffic routing algorithms are often used in practice, but these leave significant opportunities for improvement. Reinforcement learning approaches struggle with impractical compute requirements, whereas generic deep learning approaches fail to incorporate the known spatial-temporal structure of the FAB's transport system.

Our research seeks to model simulated traffic in a FAB using state-of-the-art spatial-temporal graph neural networks (STGNNs). STGNNs simultaneously model the spatial structure of the transport system via graph convolutional layers and the temporal structure of the transport system via gated units. STGNNs have been previously applied to generic traffic flow problems, but they have not yet been used to realize improvements to routing efficiency in AMHS. In this work, we demonstrate the efficacy of STGNNs for modeling FAB traffic under both standard and anomalous production conditions. Our results indicate that leveraging the FAB's physical structure results in a better model without the need for additional compute resources.

3D-Printed, Low-cost, Miniature Liquid Pumps for Compact Systems

8.07

A. P. Taylor, L. F. Velásquez-García

Sponsorship: *Edwards Vacuum*



Anthony P. Taylor
anthonyt@mit.edu

Portable microfluidic systems use pumps to precisely set flow rates of liquid. Pumps made via standard (i.e., cleanroom) microfabrication typically cannot deliver large flow rates due to their small pump chambers. Alternatively, 3D-printing has been explored as a processing arena for microsystems capable of producing larger pump chambers. We have printed miniature liquid pumps using a method whereby a nylon filament is extruded from a hot nozzle to create a solid object layer by layer.

Our low-cost, leak-tight, devices are microfabricated using a multi-step printing process (Fig. 1). Each pump has a frame and a 150- μm -thick membrane connected at its center to a piston with an embedded magnet, chamber, passive ball valves, and two fluidic connectors (Fig. 2). Pumps are made in < 2 hours and costs < \$4.65 are achieved with a maximum water flow rate of 1.37 ml/min @ 15.1 Hz actuation frequency, comparable to reported values of miniature liquid pumps with >200X higher actuation frequency.

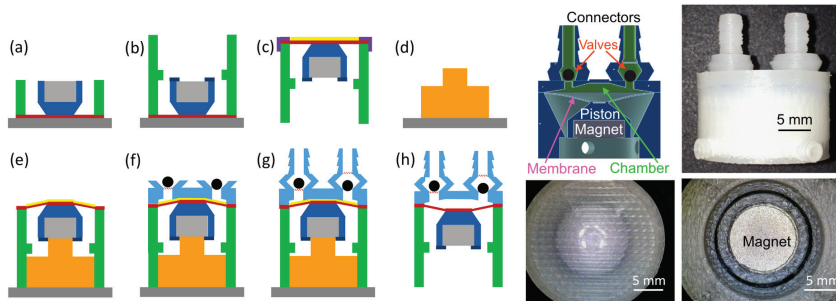

Fig. 1

Fig. 2

▲ (Fig. 1) Schematic of the process flow and (Fig. 2) cross section of pump model; side view of printed pump; bottom view of printed pump with embedded SmCo magnet; top view of pump membrane, prior to printing second half.

Protocol to Relate Breakdown Voltage and Vertical Displacement in SiNx-Au Microcantilevers

8.08

D. Grey-Stewart

Sponsorship: *MIT.nano, MIT EECS*



Danielle Grey-Stewart
dgreyste@mit.edu

Microfabrication is a dynamic, cutting edge field, but with such advanced technology comes prohibitive operational costs. One way to reduce costs, and open microfabrication exploration to a wider range of scientists, is to circumvent the use of expensive equipment. Measuring the vertical displacement of devices such as cantilevers requires costly machinery that can only be operated within the confines of a clean room. A new method of measuring the vertical displacement of a cantilever is hypothesized by quantifying the relationship between breakdown voltage and displacement. This method, which would be low-cost, effective, and repeatable, presents a new way to develop teaching modules that exemplify important phenomena in microfabrication and electrical engineering. A system of opposing cantilevers separated by an 8 μm air gap was designed, fabricated, and tested. In this system, breakdown voltage was not reached due to constraints of the electrical probe station, but proposed redesigns show a promising method to accomplish the goal of quantifying the relationship between breakdown voltage and vertical displacement.



Ella Richards
ellar@mit.edu

Microfluidic Manufacturing Analysis for Microemulsion Generation

8.09

E. V. Richards

Sponsorship: MIT.nano

When choosing a fabrication process for microfluidic devices, it is important to understand the trade-offs of different manufacturing methods. Soft lithography and lamination techniques were synthesized and examined for micro-emulsion generating chips. Both methods were comparable in cost and manufacturing time. Only the lamination chip successfully produced an emulsion with monodisperse droplets 20 micrometers in diameter. The soft lithography chip was flexible, unlike the rigid lamination chip, which caused a channel collapse in the inlets when placed under pressure. Lamination method was found to be more reliable for microemulsion generation.



Blair Anaman Williams
blairaw@mit.edu

The Effect of Geometry on the Sorting Capabilities of Microfluidic Devices

8.10

B. A. Williams

Sponsorship: MIT.nano, MIT EECS

Microfluidic devices can be used in applications that require sorting. A standard geometry used in sorting applications is an Archimedean loop consisting of circular spirals. An experiment was initially conducted to investigate how changing the geometry of the loops would affect the sorting ability of a microfluidic device. Later the effect of geometry on a device's ability to cause particles to equilibrate was investigated instead. Two microfluidic devices with outer turns having different radii were manufactured. One device had turns consisting of only right angles. The other device had turns with an outer radius of 1200 μm . Both devices were tested by pumping fluid containing microspheres in them. In a comparison between the two microfluidic devices, the 1200 μm device was found to cause microbeads to equilibrate more on average into a smaller number of streams than the right-angle device. Furthermore, it was found that the equilibration of beads became more prominent in the fifth loop of the device (farthest out) than the first loop. Therefore, it can be inferred that the 1200 μm was a better sorting device.

Formation of J-aggregates on the Interface in Microfluidics

8.11

A. Alghonaim

Sponsorship: MIT.nano, MIT EECS

J-aggregates, a class of ordered organic matter, primarily composed of cyanine dyes exhibit a red shift in their absorption peak relative to the dye monomers. The physics of the aggregate formation in these dyes is difficult to understand. Herein, we explore the aggregate formation with the aid of microfluidic devices wherein the channel dimensions enable laminar flow of the dye solution. Such tools limit turbulent mixing, allowing diffusive transport to dominate, which enables one to get a better understanding of the aggregate formation under controlled environments. In this study the formation of J-aggregates at the interface in laminar flow was observed, but the aggregation wasn't controlled due to experimental limitations. The fluorescence of the J-aggregates of pseudoisocyanine iodide was observed.

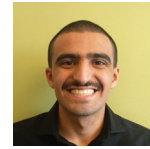

Abdulmalik Alghonaim
abdulmlk@mit.edu

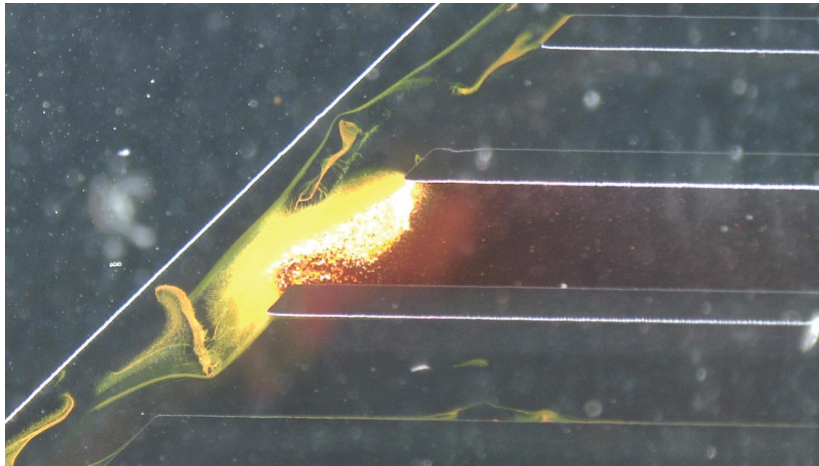

▲ An optical microscope in reflection mode with a black background. The Image is of a blockage that occurred in the channel due to the formation of the PIC J-aggregates.

Delivering In-Plane Light to μ Fluidic Devices For Optical Manipulation

8.12

M. Dubrovsky

Sponsorship: MIT.nano, MIT EECS

Optical manipulation is emerging as a powerful tool, alongside optical spectroscopy, for creating functional microfluidic devices. Light can be used to sort, trap, or manipulate cells, plasmonic nanoparticles, and dielectric particles. It can also be used to drive flow in microfluidic devices and to actuate microfabricated pumps.

In this work, PDMS structures were fabricated and tested for delivering in-plane light to microfluidic devices for sorting nanoparticles. Several designs were investigated including immersion oil-PDMS waveguides, micro-fabricated lenses, and channels for inserting fiber optic cables. We identify practical challenges for simple fabrication and testing methods and discuss possible design remedies for each structure. The immersion oil waveguides were found to be workable, but simple laser coupling was challenging and resulted in lossy connections. The micro-fabricated lenses proved difficult to test and the fiber channel fabrication failed repeatedly as the necessary channel height (~130 microns) for fiber insertion was outside the standard capabilities of the photoresist available. A thicker resist or improved double-layer coated resist process may help address these challenges in the future.

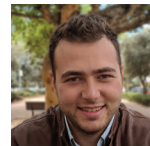

Michael Dubrovsky
mdubrov@mit.edu

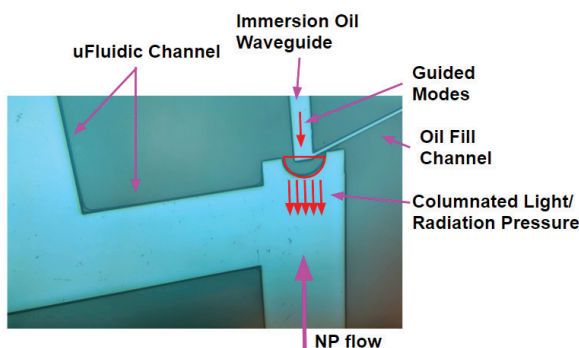

◀ Optical micrograph of immersion oil-PDMS waveguide, and microfabricated PDSM-water lens adjoining plasmonic nanoparticle sorting μ fluidic device.

MAPS

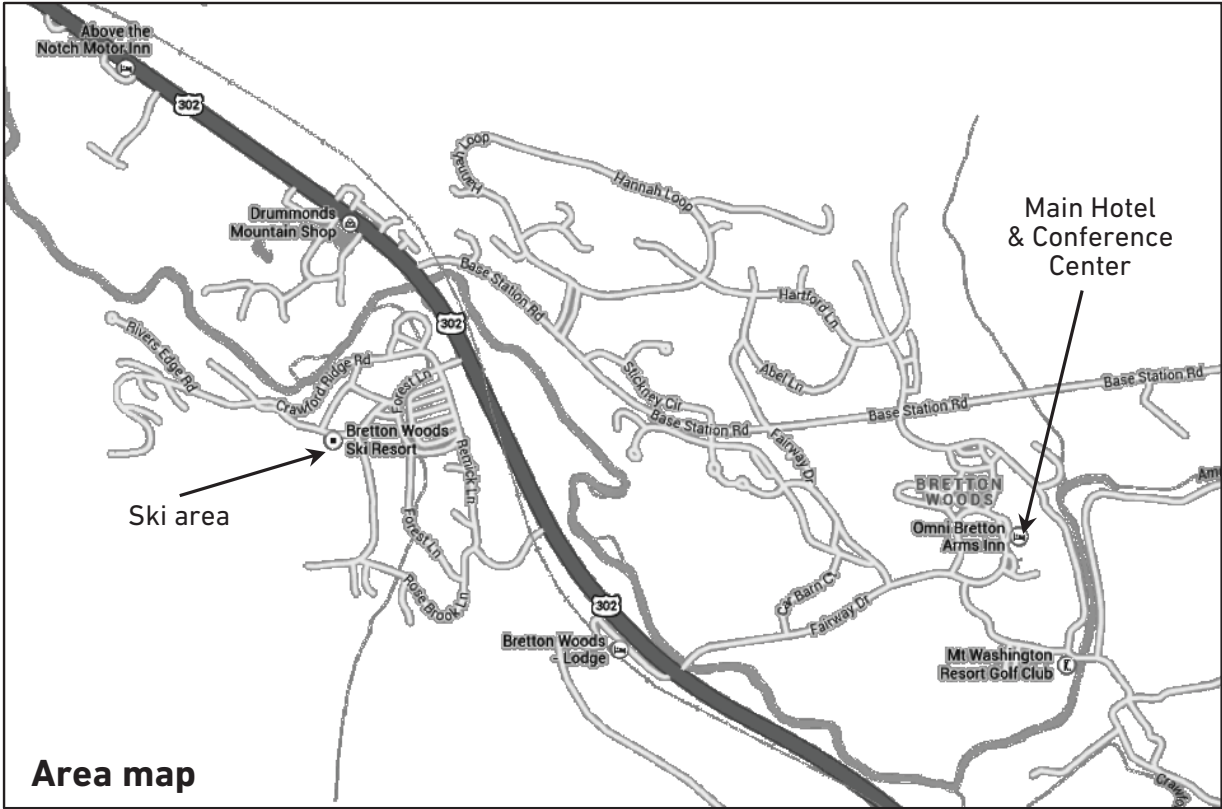

Mount Washington Great Hall Level

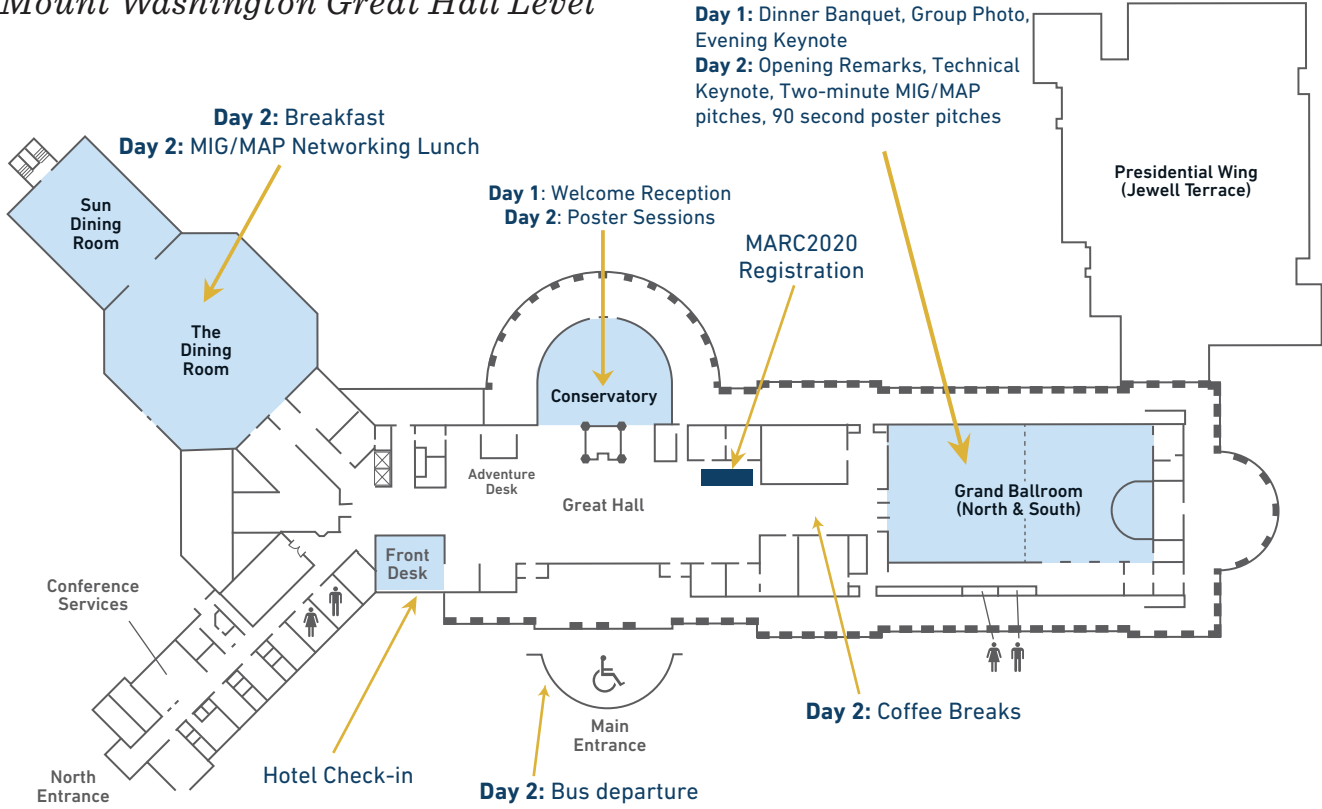

DAY 1: LOWER LEVEL

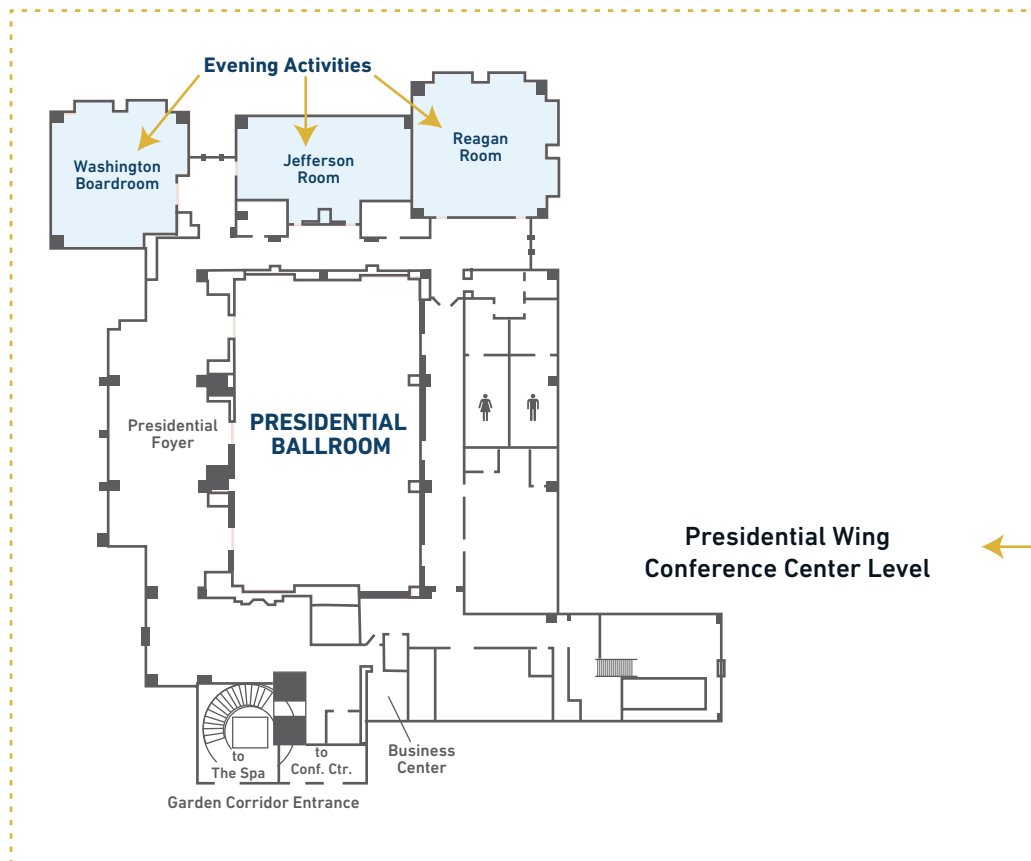
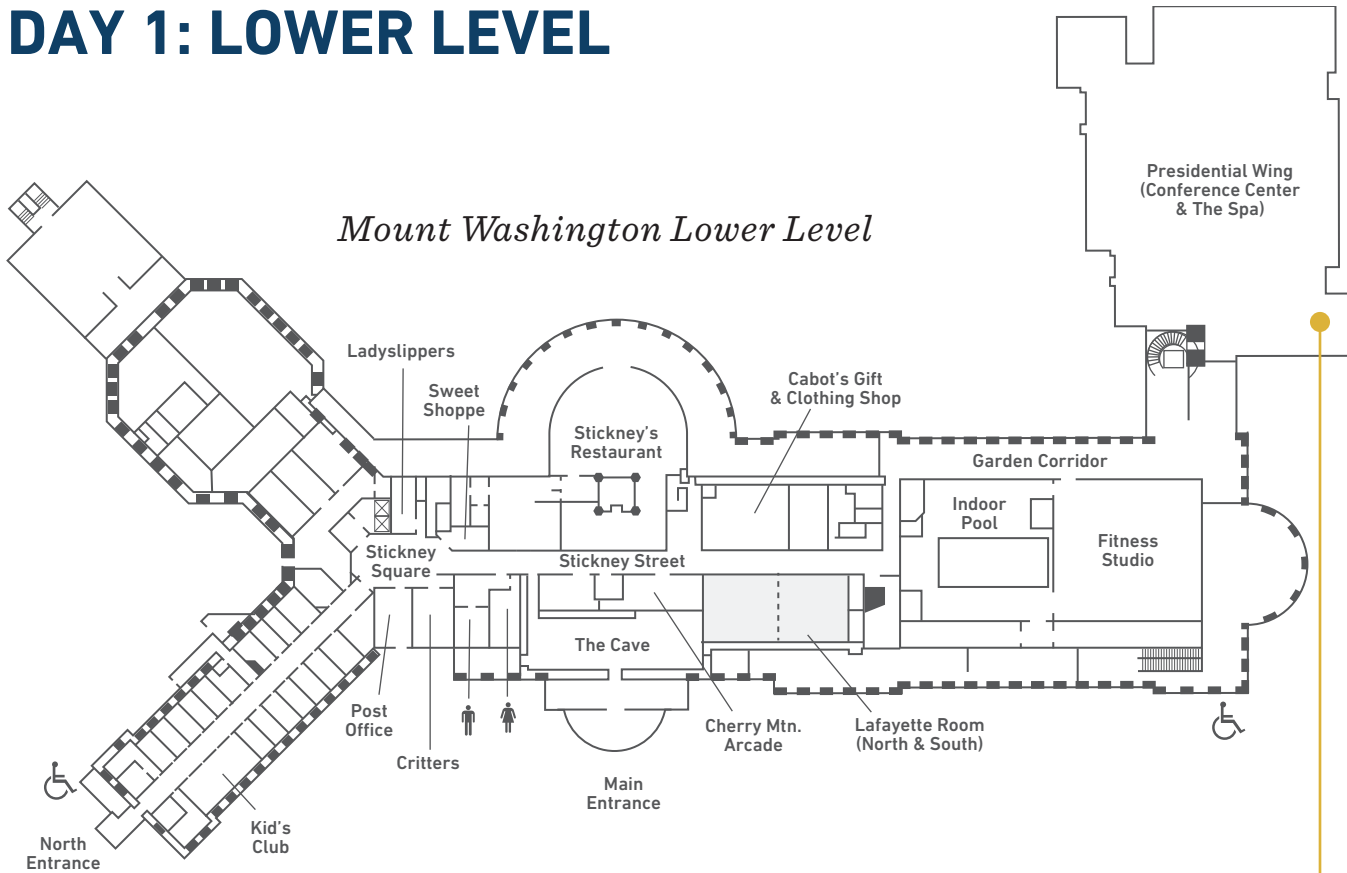

ONE.MIT: MANY GENERATIONS, ONE COMMUNITY.

MIT's Great Dome has come to symbolize our distinctive community of scientists and scholars, inventors and innovators. Now, in a permanent installation at MIT.nano, their names combine to form a mosaic of the Great Dome etched into the surface of a six-inch silicon wafer.

How many names make up the image? A team organized by MIT.nano and led by Annie Wang, research scientist for MIT.nano special projects, identified more than 270,000 students, alumni, faculty, and staff from MIT's founding in 1861 to April 2018. MIT POSCO Professor of Materials Science and Engineering (DMSE) and MacVicar Faculty Fellow W. Craig Carter created the algorithms that determined the placement of each name and the global text size to maximally fill the printing space—a nonlinear optimization problem. Each letter had to be turned into a graphical curve object and modified to be light or dark, coming together like pixels to depict the Dome.

Using photolithography and etch processes designed for micro- and nanotechnology, the final image was etched onto a silicon wafer in the Microsystems Technology Laboratory (MTL). Imagined at MIT.nano and created with the tools of MTL, this art piece exemplifies the close collaboration of these two labs that now, together, bring you MARC 2020.

Learn more and find your own name at onemit.mit.edu.



MTL ● MICROSYSTEMS
● TECHNOLOGY
● LABORATORIES

MIT.nano