

---

# Fast On-Chip Control Circuitry

---

## Personnel

D. S. Crankshaw, J. Habif, D. Nakada, M. Feldman, M. Bocko, K. Berggren

## Sponsorship

ARO, DURINT

RSFQ (Rapid Single Flux Quantum) electronics can provide digital circuitry which operates at speeds ranging from 1 - 100 GHz. If these electronics can be integrated onto the same chip as the qubit, complicated control with precise timing can be applied to the qubit by on-chip elements. The following design is currently in fabrication.

An RSFQ clock can be used as the oscillator to rotate the PC qubit. This oscillator has more frequency components and less tunability than a DC SQUID, but it is easier to use in conjunction with other RSFQ components. In the following design, these components can deliver a variable frequency signal. An RSFQ clock is simply a Josephson Transmission Line ring. The transmission line propagates a pulse in its loop, which can be tapped off and used as a clock signal. Two counters and a Non-Destructive Read Out (NDRO) memory cell

make up the digital pulse width modulator. The signal from the clock goes to both counters and to the Read input of the NDRO. The NDRO outputs a 1 for each clock input if a 1 is stored in it, but no output for each pulse if a 0 is stored in it. The output of the counters go to the Set (which sets the NDRO to 1) and the Reset (which resets the NDRO to 0) inputs of the NDRO. The counters are equal in length (13 bits), so that after 213 pulses, each one sends its output to the NDRO. By initially offsetting the counters by pre-loading them with the Offset inputs, one can set them out-of-phase with one another, thus controlling the duty cycle of the NDRO output. Since the NDRO signal has lots of harmonics, an RLC resonance filters the signal before delivering it to the qubit. The resonance filter converts the highly non-linear clock signal to a nearly sinusoidal signal.

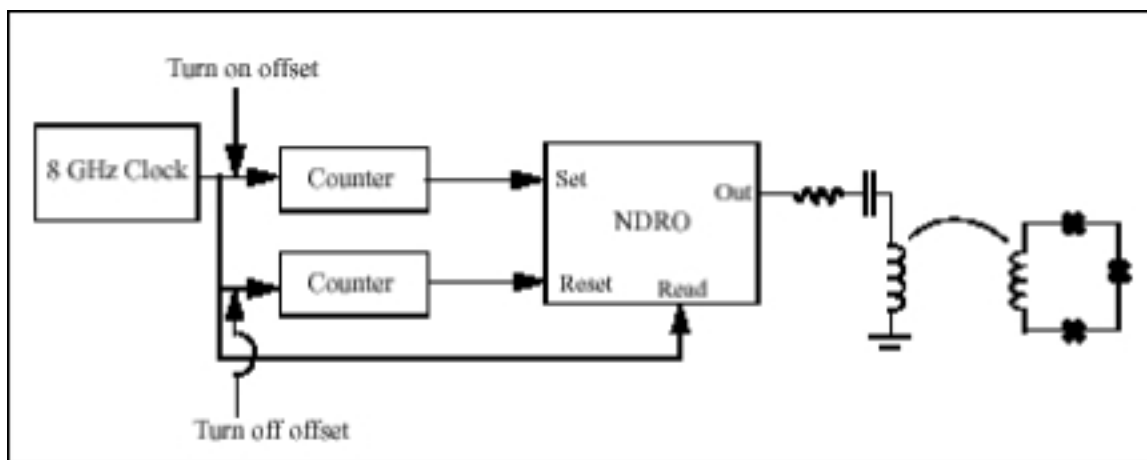

Fig. 7: Variable duty cycle oscillator.

---